

Summer Block 1

Decimals B

Small steps

Step 1

Make a whole with tenths

Step 2

Make a whole with hundredths

Step 3

Partition decimals

Step 4

Flexibly partition decimals

Step 5

Compare decimals

Step 6

Order decimals

Step 7

Round to the nearest whole number

Step 8

Halves and quarters as decimals



Make a whole with tenths

Notes and guidance

In this small step, children explore different ways of making 1 whole by combining tenths. Encourage children to use number bonds to 10 to support them, for example using $6 + 4$ when finding the missing number in $0.6 + \underline{\quad} = 1$

Representations such as ten frames, place value counters, double-sided counters, hundred squares, bead strings and Rekenreks support children to visually see the connections to 1 whole. Part-whole models and bar models can also be used.

It is important that children recognise that, for example, $\frac{2}{10}$ is equal to 0.2, so they can write $\frac{2}{10} + \frac{8}{10}$ or $\frac{2}{10} + 0.8$. They could be challenged to find the whole from more than two parts, for example $1 = 0.3 + 0.4 + 0.3$

Things to look out for

- When finding 1 whole, children may confuse tenths and hundredths by incorrectly using a zero as a placeholder, for example $0.06 + 0.04 = 1$
- Children may not realise that it is possible to make 1 whole by adding a fraction and a decimal, for example $\frac{1}{10} + 0.9 = 1$

Key questions

- How many tenths make 1 whole?
- How many equal parts is 1 whole split into for one tenth to be one of the parts?
- What is the number bond of $\underline{\quad}$ to 10?
- What is the number bond of $\underline{\quad}$ tenths to 1 whole?
- What is the same/different about $7 + 3$ and 7 tenths + 3 tenths?
- If you have $\underline{\quad}$ tenths, how many more tenths do you need to make 1 whole?

Possible sentence stems

- $\underline{\quad} + \underline{\quad} = 10$,
so $\underline{\quad}$ tenths + $\underline{\quad}$ tenths = 1 whole
- $\frac{\square}{10} = 0.\underline{\quad}$

National Curriculum links

- Recognise and write decimal equivalents of any number of tenths or hundredths
- Solve simple measure and money problems involving fractions and decimals to 2 decimal places

Make a whole with tenths

Key learning

- Aisha uses a ten frame and counters to show the addition $0.9 + 0.1 = 1$

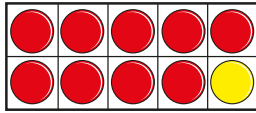

Use a ten frame and counters to find different ways to make 1 whole.

- The hundred square represents 1 whole.

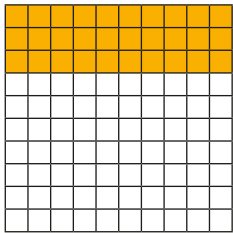

How many tenths are shaded?

How many more tenths need to be shaded so that the whole hundred square is shaded?

_____ tenths + _____ tenths = 1 whole

- Here is a Rekenrek with 100 beads.

Each row of beads is equal to one tenth of the whole.

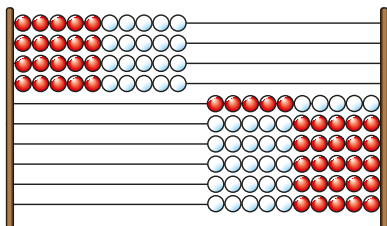

_____ tenths are on the left.

_____ tenths are on the right.

_____ + _____ = 1 whole

- Complete the part-whole models.

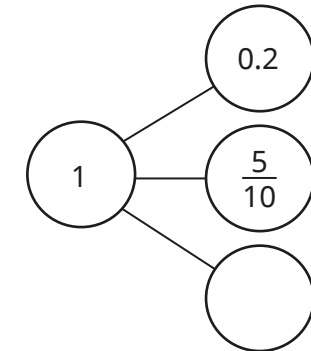
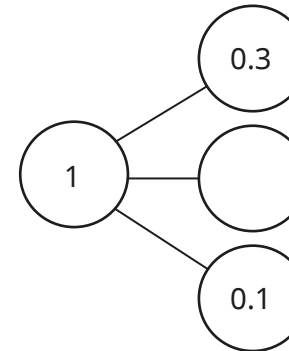
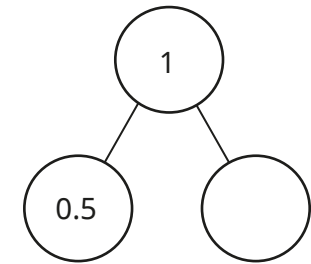
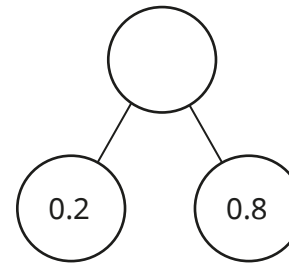

- Complete the number sentences.

▶ $0.1 + \underline{\quad} = 1$

▶ $1 = 0.2 + \underline{\quad}$

▶ $0.7 + 0.3 = \underline{\quad}$

▶ $\underline{\quad} + 0.5 = 1$

▶ $\frac{2}{10} + 0.8 = \underline{\quad}$

▶ $1 = \frac{6}{10} + \underline{\quad}$

▶ $1 = \underline{\quad} + 0.5 + 0.1$

▶ $\frac{3}{10} + 0.4 + \underline{\quad} = 1$

Make a whole with tenths

Reasoning and problem solving



Tiny draws a part-whole model.

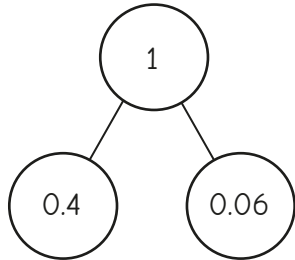

No

Is Tiny's part-whole model correct?

Explain how you know.



Which calculation is the odd one out?

$$0.5 + 0.5$$

$$0.3 + 0.5 + 0.2$$

$$0.08 + 0.02$$

$$0.1 + 0.9$$

any with correct justification, e.g. $0.08 + 0.02$ is not a bond to 1

Explain your answer.



Sam has some 0.1 counters and some $\frac{1}{10}$ counters.

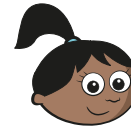

The total of my counters is 1 whole.

She gives 3 of her 0.1 counters to Ron.

She gives 2 of her $\frac{1}{10}$ counters to Dora.

What counters could she have left?

How many answers can you find?



multiple possible answers, e.g.

$$1 \times 0.1 \text{ and } 4 \times \frac{1}{10}$$

Find four different ways to complete the number sentence.



$$\boxed{} + 0.1 + \boxed{} = 1$$

0.1 and 0.8, 0.2 and 0.7, 0.3 and 0.6, 0.4 and 0.5

The numbers can be either way round.

Make a whole with hundredths

Notes and guidance

This small step builds on the previous step, as children now explore different ways of making 1 whole from hundredths.

This step requires children to use their number bonds to 100. Initially, they may need to practise finding number bonds to 100 that are multiples of 10, such as $60 + \underline{\quad} = 100$. Then they can move on to the number bond to 100 for any 2-digit number, such as $63 + \underline{\quad} = 100$

Using a familiar context, such as measurements involving centimetres and metres, can support children to make a whole from hundredths, using the fact that $1 \text{ cm} = \frac{1}{100} \text{ m}$.

Things to look out for

- If number bonds to 100 are not secure, children may make bridging errors such as $74 \text{ hundredths} + 36 \text{ hundredths} = 1 \text{ whole}$.
- When finding a whole, children may confuse tenths and hundredths, for example $0.09 + 0.01 = 1$
- Children may not realise that it is possible to make 1 whole by adding a fraction and a decimal, for example $\frac{34}{100} + 0.66 = 1$

Key questions

- How many hundredths make 1 whole?
- How many equal parts is 1 whole split into for one hundredth to be one of the parts?
- What is the number bond of $\underline{\quad}$ to 100?
- What is the number bond of $\underline{\quad}$ hundredths to 1 whole?
- What is the same/different about $4 + 6$, $4 \text{ tenths} + 6 \text{ tenths}$ and $40 \text{ hundredths} + 60 \text{ hundredths}$?
- If you have $\underline{\quad}$ hundredths, how many more do you need to make 1 whole?

Possible sentence stems

- $\underline{\quad} + \underline{\quad} = 100$,
so $\underline{\quad}$ hundredths + $\underline{\quad}$ hundredths = 1 whole
- $\frac{\square}{100} = 0.\underline{\quad}$

National Curriculum links

- Recognise and write decimal equivalents of any number of tenths or hundredths
- Solve simple measure and money problems involving fractions and decimals to 2 decimal places

Make a whole with hundredths

Key learning

- The hundred square represents 1 whole.

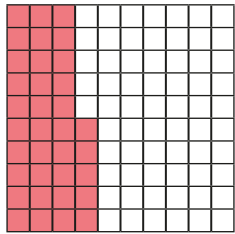

How many hundredths are shaded?

How many more hundredths need to be shaded so that the whole hundred square is shaded?

_____ hundredths + _____ hundredths = 1 whole

- Here is a Rekenrek with 100 beads.

Each bead is one hundredth of the whole.

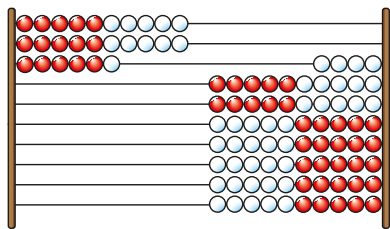

_____ hundredths are on the left.

_____ hundredths are on the right.

_____ + _____ = 1 whole

- Complete the bar models.

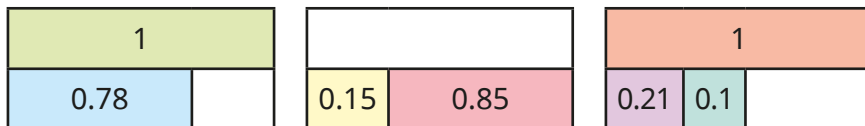

- Complete the number sentences.

- ▶ 4 hundredths + _____ hundredths = 1
- ▶ _____ hundredths + 83 hundredths = 1
- ▶ _____ hundredths + 13 hundredths = 1
- ▶ 24 hundredths + _____ hundredths + 6 tenths = 1

- Complete the part-whole models.

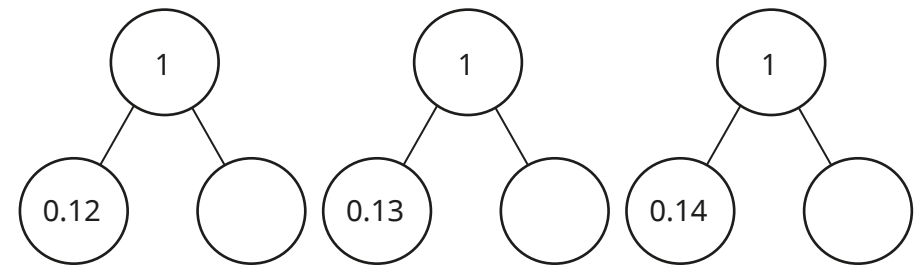

What do you notice?

- Which calculations **do not** sum to 1?

0.54 + 0.56

0.54 + 0.46

0.54 + 0.54

0.3 + 0.7

0.03 + 0.7

0.03 + 0.07

Make a whole with hundredths

Reasoning and problem solving

Tommy has a piece of ribbon that is less than 0.6 m long.



Rosie has a piece of ribbon that is less than 0.45 m long.

Altogether, could they have enough ribbon to measure exactly 1 m?

Explain your reasoning.

Yes
multiple possible answers, e.g.
 $0.56\text{ m} + 0.44\text{ m}$
 $0.57\text{ m} + 0.43\text{ m}$

Each row and column in the square sum to 1 whole.

Complete the grid.

0.44	0.45	
	0.35	
0.16		0.64

0.44	0.45	0.11
0.40	0.35	0.25
0.16	0.20	0.64

Whitney, Eva and Jack are growing flowers.



Whitney

My flower is exactly 1 m tall.

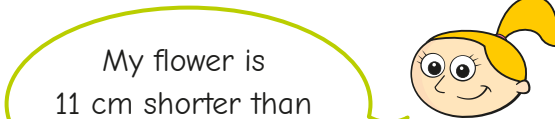

Eva

My flower is 11 cm shorter than Whitney's flower.



Jack

My flower is taller than Eva's flower, but shorter than Whitney's flower.

0.89 m

taller than 0.89 m and shorter than 1 m, e.g. 0.94 m

How tall is Eva's flower in metres?

How tall could Jack's flower be in metres?

Partition decimals

Notes and guidance

In this small step, children partition numbers with up to 2 decimal places into their place value parts.

Using place value counters and place value charts supports children in recognising the place value of each digit in a number. Part-whole models are used to partition the numbers using the children's understanding of place value.

In this step, children focus on partitioning into the ones part, the tenths part and the hundredths part. More flexible partitioning is the focus of the next step.

Discuss with children the role of zero as a placeholder. Encourage them to verbalise each place value column of a number, for example “zero tenths” in the number 3.09

Things to look out for

- Children may write decimal numbers incorrectly if they are unable to use zero as a placeholder, for example writing 7 hundredths as 0.7
- When writing a number that requires zero as a placeholder, children may not include the zero, for example $8 + 0.06 = 8.6$

Key questions

- How many ones/tenths/hundredths are there in the number?
- How do you write this number as a decimal?
- How would you read the number out loud?
- How would you partition the number into ones, tenths and hundredths?
- What is the value of _____ in the number _____?
- What is the role of zero in the number 4.06?

Possible sentence stems

- There are _____ ones, _____ tenths and _____ hundredths. The number is _____
- There are _____ ones, _____ tenths and _____ hundredths, so _____ = _____ + _____ + _____

National Curriculum links

- Recognise and write decimal equivalents of any number of tenths or hundredths
- Solve simple measure and money problems involving fractions and decimals to 2 decimal places

Partition decimals

Key learning

- Complete the sentences to describe the numbers shown in the place value charts.

There are _____ ones, _____ tenths and _____ hundredths.

The number is _____

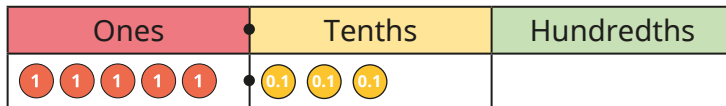
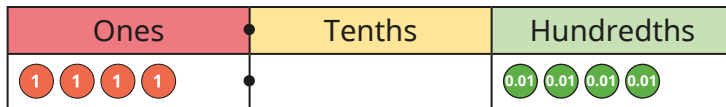
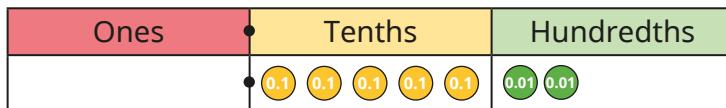
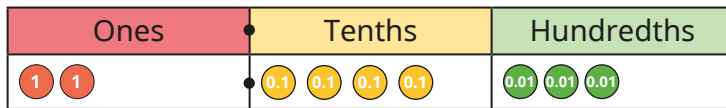

- Use place value counters to make the numbers.

Partition each number into ones, tenths and hundredths.



- Complete the part-whole models and the number sentences.

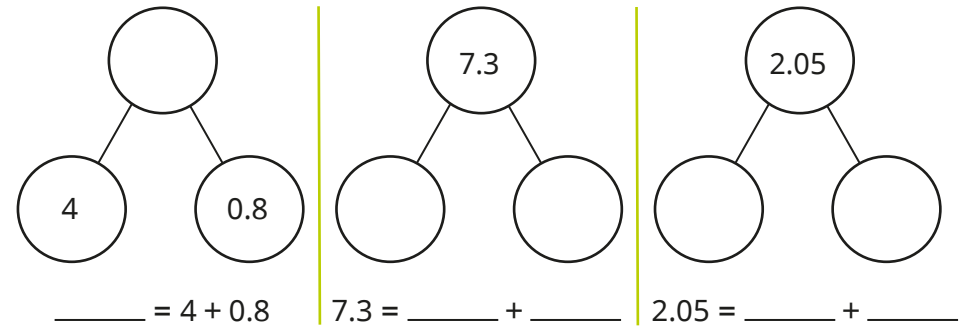

- Complete the part-whole models.

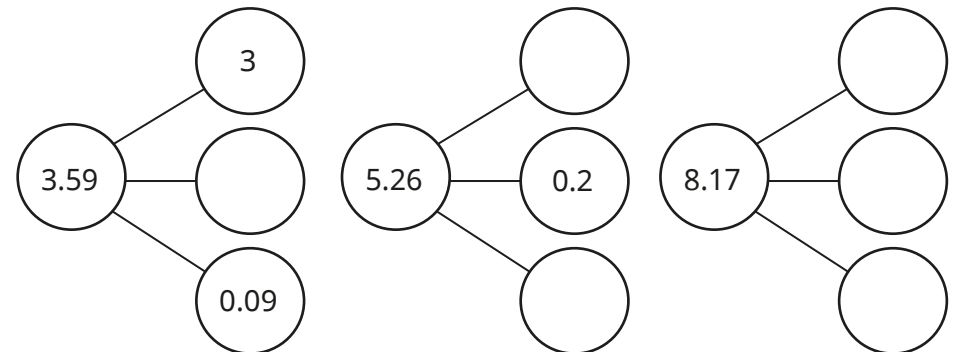

- Make each number on a place value chart.

Write the value of the underlined digit.



Partition decimals

Reasoning and problem solving

Scott is counting up in hundredths using counters in a place value chart.

He counts up to 10 hundredths.

Ones	Tenths	Hundredths

He writes the decimal as 0.010

Is Scott correct?

Explain your answer.

No

10 hundredths should be exchanged for 1 tenth.

10 hundredths or 1 tenth is written as 0.1

Ones	Tenths	Hundredths

Dani thinks that the number shown in the place value chart is 2.2

Do you agree with Dani?

Explain your answer.

No

Dani has not included zero as the placeholder.

The number is 2.02

Each child chooses one of these numbers.

0.87	1.7	0.08	1.77
------	-----	------	------



Teddy

My number has the same digit in the tenths and hundredths columns.

My number has 8 tenths.



Kim



Alex

My number has two zero placeholders.

My number has 1 decimal place.



Mo

Which child chose which number?

How do you know?



Teddy: 1.77

Kim: 0.87

Alex: 0.08

Mo: 1.7

Flexibly partition decimals

Notes and guidance

In this small step, children carry on partitioning numbers with decimals up to 2 decimal places, with the learning from the previous step being extended to include flexible partitioning.

Flexible partitioning requires secure place value knowledge, as children are expected to partition numbers in non-standard ways. They should be able to explain that, for example, 0.12 can be made up of 12 hundredths and also 1 tenth and 2 hundredths. Children also continue to explore the role of zero as a placeholder.

Place value counters, place value charts and part-whole models are still good representations to support their understanding.

Discuss whether a number can be partitioned into more or fewer parts than its number of digits.

Things to look out for

- Children may think that numbers can only be partitioned into place value columns. For example, 3.49 can only be partitioned as $3 + 0.4 + 0.09$
- When writing a number that requires zero as a placeholder, children may not take into account the place value position of each digit, for example $8 + 0.06 + 0.1 = 8.106$

Key questions

- How many ones/tenths/hundredths are there in the number?
- How do you write this number as a decimal?
- How could you partition the number into ones, tenths and hundredths?
- How many other ways can you partition the number?
- What is the role of zero in the number 3.06?

Possible sentence stems

- The number is _____
There are _____ ones, _____ tenths and _____ hundredths.
This could be partitioned into _____ ones, _____ tenths and _____ hundredths.
- _____ = _____ + _____ + _____

National Curriculum links

- Recognise and write decimal equivalents of any number of tenths or hundredths
- Solve simple measure and money problems involving fractions and decimals to 2 decimal places

Flexibly partition decimals

Key learning

- Esther represents the number 3.52 on a place value chart.

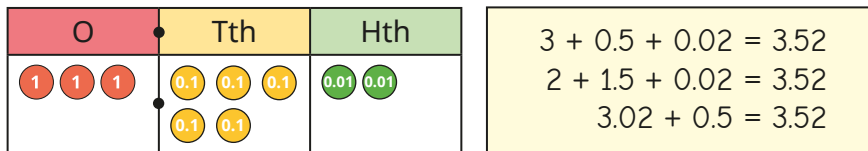

Make a different decimal number on a place value chart.

Partition your number in three different ways.

- Filip uses part-whole models to partition 0.65 in three different ways.

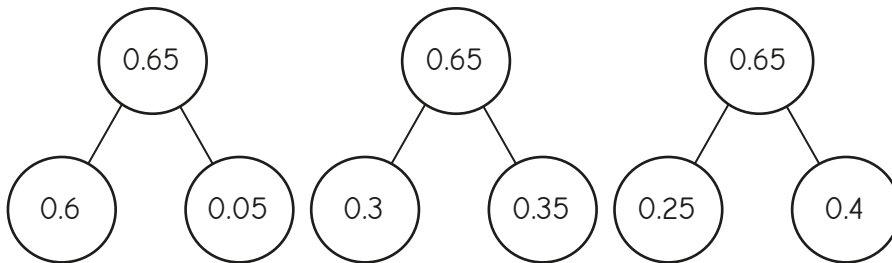

Use a part-whole model to partition 0.49 in three different ways.

Compare answers with a partner.

- The place value counters show 3.65



Use place value counters to partition 3.65 in three different ways.

Complete the number sentence for each way.

$$3.65 = \underline{\quad} + \underline{\quad} + \underline{\quad}$$

Compare answers with a partner.

- Brett has created a number on a Gattegno chart.

1	2	3	4	5	6	7	8	9
0.1	0.2	0.3	0.4	0.5	0.6	0.7	0.8	0.9
0.01	0.02	0.03	0.04	0.05	0.06	0.07	0.08	0.09

- ▶ What is Brett's number?
- ▶ Partition his number in three different ways.

- Complete the number sentences.

- ▶ $3 + 0.08 + 0.4 = \underline{\quad}$
- ▶ $0.7 + 0.04 + 30 = \underline{\quad}$
- ▶ $5 + \underline{\quad} + 0.3 = 5.36$
- ▶ $5 + \underline{\quad} + 0.2 = 5.36$
- ▶ $7 + \underline{\quad} + 0.1 = 7.34$
- ▶ $7.1 + \underline{\quad} + 0.02 = 7.34$

Flexibly partition decimals

Reasoning and problem solving

Tiny and Whitney are partitioning 2.05

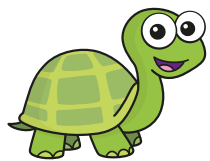

Tiny

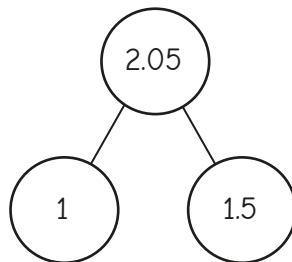

Whitney

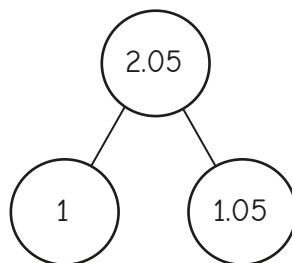

Who is correct?

Explain your answer.

Whitney

In Tiny's model,
 $1 + 1.5 = 2.5$,
not 2.05

Annie and Max are each shading a hundred square.



Annie

I have shaded 4 tenths of the hundred square in red and 26 hundredths of the hundred square in blue.

In total, I have shaded 4 fewer hundredths than Annie.



Max

How much of the hundred square has Max shaded?

Give your answer as a decimal.

Partition the decimal in three different ways.

0.62

multiple possible answers, e.g.
 $0.62 = 0.5 + 0.12$

Compare decimals

Notes and guidance

In this small step, children compare decimal numbers with up to 2 decimal places.

It is important that children consider the values of the digits in place value order, comparing digits in the greatest place value column first. Discuss whether all the place value columns need to be compared. For example, when comparing 6.73 and 2.98, only the ones need to be compared; but when comparing 5.37 and 5.39, all the places need to be compared.

Representing the numbers in place value charts supports children in recognising the value of each digit, for instance that 0.5 is less than 0.72. It is also important that children read numbers such as 0.32 as “zero point three two” rather than “zero point thirty-two”.

Things to look out for

- Children may think that a number such as 0.16 is greater than 0.3, because 16 is greater than 3
- Children may not realise that, for example, $0.4 = 0.40$
- Children may only compare the digits after the decimal point, ignoring digits to the left of the decimal point, for example $1.47 < 0.76$

Key questions

- Which place value column do you compare first? Why?
- How many ones/tenths/hundredths does the number have?
- Which number is greater/smaller? How do you know?
- How can you represent the decimal number on a place value chart?
- What is the same/different about the ones/tenths/hundredths?
- Do you need to compare every column when comparing the two numbers?

Possible sentence stems

- To compare numbers, I need to start by comparing the digits in the _____ place value column.
- _____ . _____ _____ is greater/less than _____ . _____ _____, because _____ is greater/less than _____

National Curriculum links

- Recognise and write decimal equivalents of any number of tenths or hundredths
- Compare numbers with the same number of decimal places up to 2 decimal places

Compare decimals

Key learning

- Use place value counters to make the numbers 8.4 and 4.8
Which number is greater? How do you know?
- Which is the greater of each pair of numbers?
 - ▶ 9.4 and 13.8
 - ▶ 6.3 and 5.7
 - ▶ 46.2 and 38.7
- Write < or > to compare the numbers.

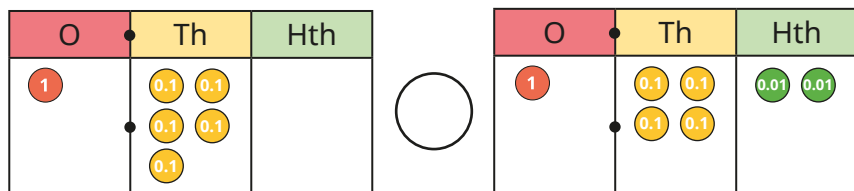
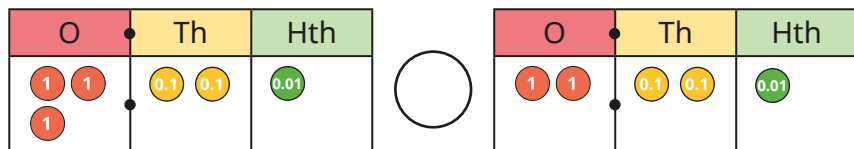
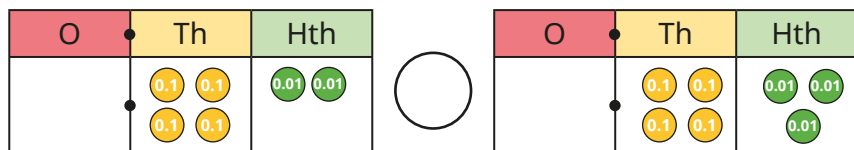

Did you have to compare all the columns for each question?

- Write < or > to compare the numbers.

$$5.8 \bigcirc 5.3 \quad 7.04 \bigcirc 7.09 \quad 0.43 \bigcirc 0.6$$

$$3.79 \bigcirc 3.71 \quad 0.9 \bigcirc 0.10 \quad 8.55 \bigcirc 8.3$$

- Fill in the missing digits to make the statements correct.

- ▶ $4.5__ > 4.53$
- ▶ $0.8__ < 0.89$
- ▶ $3.39 > 3.__9$
- ▶ $4.__8 > 4.__3$
- ▶ $0.7__ < 0.7__$
- ▶ $__.56 < __.56$
- ▶ $2.3__ > 2.1__$
- ▶ $4.09 > 4.01 + 0.0__$

- Draw exactly nine counters in the chart to represent a number that matches the description.

a number between 3.04 and 3.19

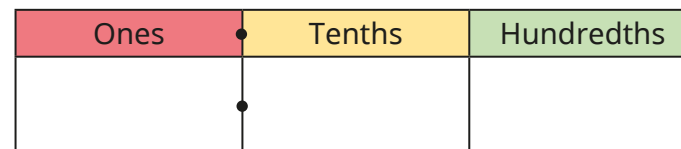

Compare answers with a partner.

Compare decimals

Reasoning and problem solving

Ron and Dexter each throw a bean bag and measure the distance of their throw.

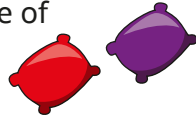

I threw the bean bag further because it landed 1.5 m away.

Ron

I threw the bean bag further because it landed 1.39 m away.



Dexter

Who is correct?

Explain your reasoning.

Ron

1.5 m is further than 1.39 m.

Use each digit card once to make the statement correct.

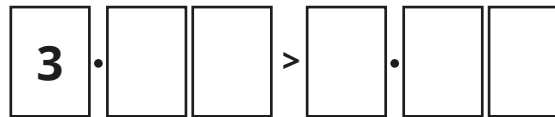
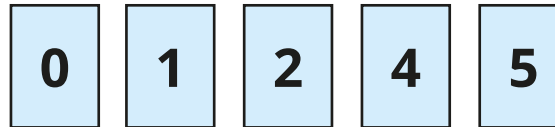

Find as many ways as you can.

multiple possible answers, e.g.

$$3.12 > 0.45$$

$$3.24 > 1.05$$

$$3.05 > 2.41$$

Tiny is comparing decimals.



0.28 is greater than 0.7 because 28 is greater than 7

Do you agree with Tiny?

Explain your reasoning.



No

Order decimals

Notes and guidance

Building on the previous step, in this small step children order decimal numbers with up to 2 decimal places. They only order numbers that have the same number of decimal places.

A wide variety of representations can be used to support ordering, including place value counters, place value charts and number lines. The learning builds on children's understanding of ordering integers in the Autumn term. Highlight the importance of looking at the values of the digits in the greatest place value column first, before moving to the next place value columns in turn.

Challenge children to order numbers that have the same digits arranged differently, to ensure that they can recognise the place value of each digit, for example $1.67 < 1.76 < 6.17 < 6.71$

Children may need reminding of the meaning of the words "ascending" and "descending".

Things to look out for

- When comparing numbers, children may order numbers using the smallest place value column first, instead of the greatest.
- Children may only compare the digits after the decimal point, ignoring digits to the left of the decimal point, for example $1.47 < 0.76$

Key questions

- Which number is the greatest/smallest? How do you know?
- Which place value column did you compare first? Why?
- How many tens/ones/tenths/hundredths does the number have?
- How can you represent the number on a place value chart?
- What is the same/different about the digits of the numbers?
- Why have you chosen to order the decimal numbers this way?
- Did you look at every place value column when ordering these numbers? Why or why not?

Possible sentence stems

- There are _____ ones, _____ tenths and _____ hundredths.
- The digit in the _____ column is _____ than the other numbers. This number is the _____

National Curriculum links

- Recognise and write decimal equivalents of any number of tenths or hundredths
- Compare numbers with the same number of decimal places up to 2 decimal places

Order decimals

Key learning

- Label the numbers on the number line.

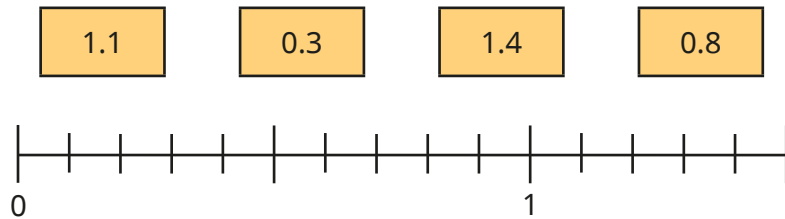

Write the numbers in order of size, starting with the smallest.

- Aisha has made three numbers on place value charts.

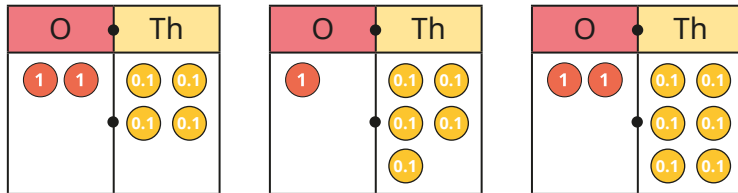

Write Aisha's numbers in order of size, starting with the greatest.

- Huan has written four numbers on place value charts.

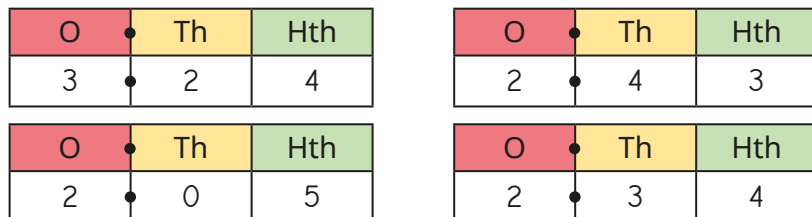

Write Huan's numbers in ascending order.

- Sam uses nine plain counters to make a number on a place value chart.

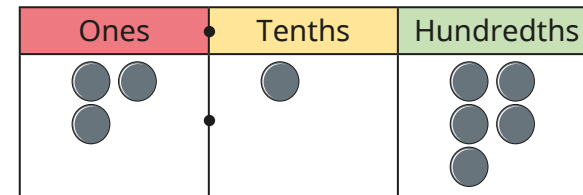

- Rearrange the counters to make a number that is less than Sam's number.
- Rearrange the counters to make a number that is greater than Sam's number.

Compare answers with a partner.

- Write the numbers in order, from smallest to greatest.

- 7.2 5.7 6.1 6.7
- 3.65 6.53 3.56 5.63
- 24.9 29.4 24.7 22.5

- The numbers are in ascending order.

3.5___ 3.5___ 3.5___ 3.5___

What could the missing digits be?

Compare answers with a partner.

Order decimals

Reasoning and problem solving

Some children planted sunflowers and measured their heights.



Child	Height
Amir	1.23 m
Tommy	0.95 m
Rosie	1.02 m
Jack	1.21 m
Eva	0.99 m

Order the children based on the heights of their sunflowers, starting with the shortest.

Tommy, Eva, Rosie, Jack, Amir



Tiny has put some numbers in order, starting with the smallest.

$$0.07 < 0.36 < 1.56 < 0.98$$

What mistake has Tiny made?

Put the numbers in the correct order.



$$0.07 < 0.36 < 0.98 < 1.56$$

The numbers are in ascending order.

$$3.\underline{\quad}6 < \underline{\quad}.83 < 5.9\underline{\quad}$$

The same digit is missing in each number.

What could the missing digit be?

Find as many ways as you can.



3, 4 or 5

Round to the nearest whole number

Notes and guidance

In this small step, children round decimals with 1 decimal place to the nearest whole number. They should be able to use the word “integer” as an alternative to “whole number”.

Children can make links to rounding to the nearest 10, 100 and 1,000 studied in the Autumn term. Again, using a number line will help children to see which whole numbers a decimal number lies between. They then consider which whole number the decimal number is nearer to, by looking at the digit in the tenths column. Using the same convention as in their earlier rounding, a number with a 5 in the tenths column, although exactly halfway between integers, rounds to the greater integer.

Children should recognise that a decimal number rounded to the nearest whole number can round to zero.

Things to look out for

- Children may be confused by language such as “round down”, rounding a number such as 5.2 to 4 instead of 5
- Children may incorrectly give answers in the form 7.0 rather than 7
- Children may round numbers such as 42.7 to the nearest 10 instead of the nearest integer.

Key questions

- Which whole numbers does _____ lie between?
- Using the number line, which whole number is _____ nearer to?
- When rounding to the nearest whole number, which place value column should you look at?
- The number has a _____ in the tenths column. When rounded to the nearest whole number, will it round to _____ or _____?
- What is the same/different about rounding to the nearest whole number and rounding to the nearest ten?

Possible sentence stems

- _____ lies between _____ and _____
- _____ is closer to _____ than _____
- _____ rounds to _____ to the nearest whole number.

National Curriculum links

- Recognise and write decimal equivalents of any number of tenths or hundredths
- Round decimals with 1 decimal place to the nearest whole number

Round to the nearest whole number

Key learning

- Draw arrows to estimate the positions of the numbers on the number line.

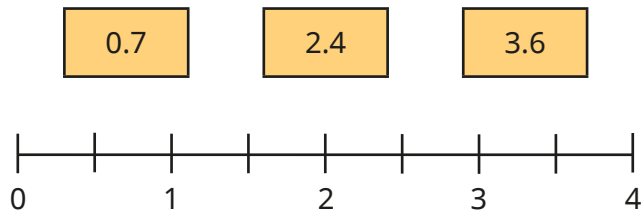

- Fill in the integers on the number lines.

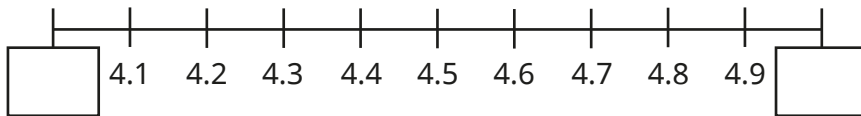
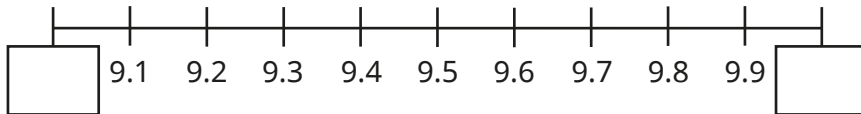

- Which integers do the numbers lie between?
 - ▶ 1.7 lies between _____ and _____
 - ▶ 5.1 lies between _____ and _____
 - ▶ 8.3 lies between _____ and _____
 - ▶ 7.5 lies between _____ and _____

- Label 6.2 on the number line.

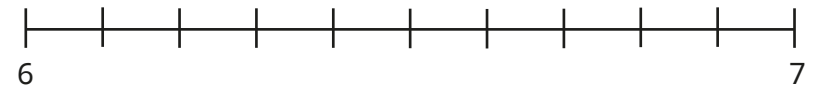

Is 6.2 closer to 6 or 7?

Complete the sentence.

_____ rounded to the nearest whole number is _____

- Label 14.7 on the number line.

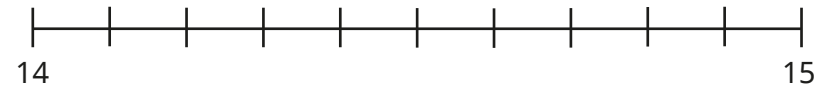

Complete the sentence.

_____ rounded to the nearest whole number is _____

- Round the numbers to the nearest whole number.



- Which numbers round to 14, when rounded to the nearest whole number?

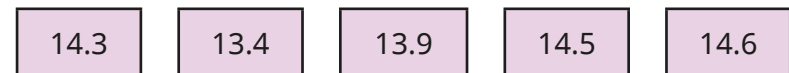

Round to the nearest whole number

Reasoning and problem solving

When a number with 1 decimal place is rounded to the nearest whole number, the answer is 64

Could the number be 63.5?

Could the number be 64.5?

What could the number be?

Yes

No

63.5, 63.6, 63.7,
63.8, 63.9, 64.0,
64.1, 64.2, 64.3, 64.4

Tiny is rounding 0.4 to the nearest whole number.



0.4 rounded to the nearest whole number is 1

Do you agree with Tiny?

Explain your answer.

No

Use the digit cards to complete the sentences.

You may use a digit card once only in each set of sentences.

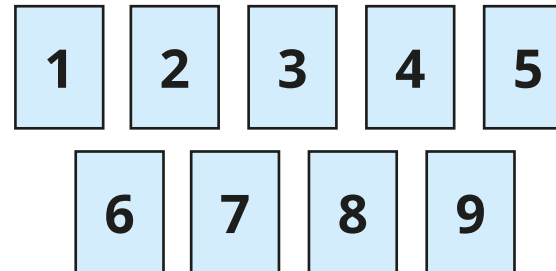

_____ . _____ rounded to the nearest whole number is 4

_____ . _____ rounded to the nearest whole number is 6

_____ . _____ rounded to the nearest whole number is 9

Find as many ways as you can.

multiple possible answers, e.g.

3.8, 4.2, 3.6

5.6, 6.1, 5.9

9.4, 8.9, 8.7

Halves and quarters as decimals

Notes and guidance

In this small step, children apply their knowledge of decimal equivalents of hundredths and tenths to recognise and write $\frac{1}{4}$, $\frac{1}{2}$ and $\frac{3}{4}$ as decimals.

A blank hundred square, a number line or a Rekenrek are all useful representations to support conversion between these fractions and decimals, as children can see how many hundredths each fraction is worth and then apply their knowledge from previous steps. They can also use a place value chart and place value counters to represent $\frac{1}{4}$, $\frac{1}{2}$ and $\frac{3}{4}$ as decimals.

Extend children's understanding by considering decimal equivalents to fractions that are equivalent fractions to $\frac{1}{4}$, $\frac{1}{2}$ and $\frac{3}{4}$

Things to look out for

- Children may incorrectly use the denominator and numerator as a reference, for example $\frac{1}{2} = 0.2$ or 1.2 , $\frac{1}{4} = 0.4$ or 1.4 , $\frac{3}{4} = 0.34$ or 3.4
- Children may think $0.5 < 0.25$ because $5 < 25$

Key questions

- How can you show one quarter/one half/three-quarters on a hundred square?
- How many hundredths are the same as $\frac{1}{4}$ / $\frac{1}{2}$ / $\frac{3}{4}$?
- What is the decimal equivalent of $\frac{1}{4}$ / $\frac{1}{2}$ / $\frac{3}{4}$?
- How would you write the fraction as a decimal?
- Are _____ and _____ equivalent fractions?
How do you know?

Possible sentence stems

- $\frac{1}{2} = \frac{\square}{100} = 0.\underline{\quad}$
- $\frac{1}{4} = \frac{\square}{100} = 0.\underline{\quad}$
- $\frac{3}{4} = \frac{\square}{100} = 0.\underline{\quad}$

National Curriculum links

- Recognise and write decimal equivalents of any number of tenths or hundredths
- Recognise and write decimal equivalents to $\frac{1}{4}$, $\frac{1}{2}$ and $\frac{3}{4}$

Halves and quarters as decimals

Key learning

- Here is a blank hundred square.

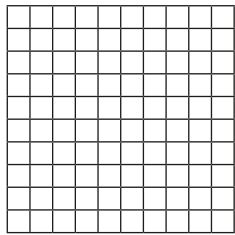

Shade half of the hundred square.

How many squares are shaded?

Complete the equivalent fraction. $\frac{\square}{2} = \frac{\square}{100}$

Write $\frac{1}{2}$ as a decimal.

- $\frac{1}{4}$ has been shaded on both hundred squares.

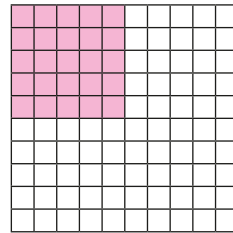
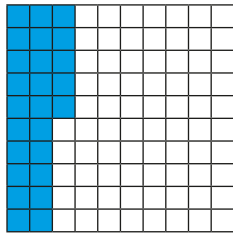

What do you notice?

How many hundredths are shaded?

Write $\frac{1}{4}$ as a decimal.

- Draw place value counters to show the decimal equivalent of $\frac{3}{4}$

Ones	Tenths	Hundredths
●	●	

- Fill in the missing fractions and decimals on the number lines.

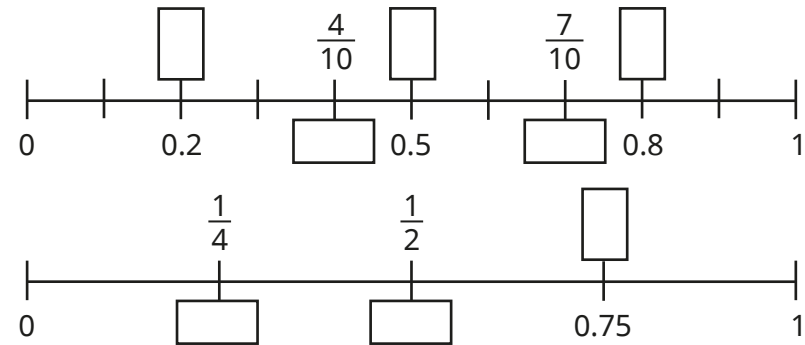

- Shade three-quarters of the bar model and complete the sentence.

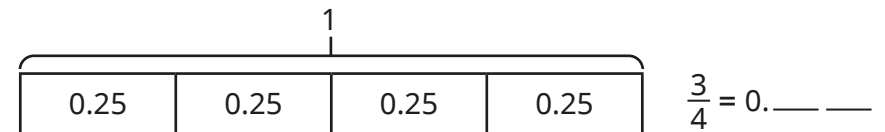

- Match the fractions to their decimal equivalents.

$\frac{1}{2}$	$\frac{1}{10}$	$\frac{1}{4}$	$\frac{1}{100}$	$\frac{3}{4}$
0.25	0.1	0.75	0.5	0.01

Halves and quarters as decimals

Reasoning and problem solving

Alex is converting fractions to decimals.

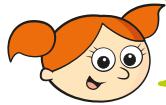

If I know $\frac{1}{2}$ is 0.5 as a decimal, I know $\frac{3}{6}$, $\frac{4}{8}$ and $\frac{6}{12}$ are also equivalent to 0.5

$\frac{3}{6}$, $\frac{4}{8}$ and $\frac{6}{12}$ are equivalent fractions to $\frac{1}{2}$, so they are all equivalent to 0.5

Explain Alex's thinking.

Which is the odd one out?

$\frac{75}{100}$	$\frac{3}{4}$	0.75
$\frac{7}{10}$	$\frac{15}{20}$	

$\frac{7}{10}$, because $\frac{75}{100} = \frac{3}{4} = 0.75 = \frac{15}{20}$

Explain your reasoning.

Teddy is converting fractions to decimals.

$$\frac{1}{2} = 1.2 \quad \frac{1}{4} = 1.4 \quad \frac{3}{4} = 3.4$$

No

Do you agree with Teddy?

Explain your reasoning.



Kim writes fractions as decimals using a place value chart.

She represents $\frac{5}{10}$ like this.

Ones	Tenths
0	5

She represents $\frac{1}{2}$ like this.

Ones	Tenths
0	2

No
Kim has correctly converted $\frac{5}{10}$ to a decimal, but $\frac{1}{2}$ is equivalent to $\frac{5}{10}$, so $\frac{1}{2} = 0.5$

Do you agree with Kim?

Explain your reasoning.