

Spring Block 2

Length and perimeter

Small steps

Step 1

Measure in metres and centimetres

Step 2

Measure in millimetres

Step 3

Measure in centimetres and millimetres

Step 4

Metres, centimetres and millimetres

Step 5

Equivalent lengths (metres and centimetres)

Step 6

Equivalent lengths (centimetres and millimetres)

Step 7

Compare lengths

Step 8

Add lengths



Small steps

Step 9

Subtract lengths

Step 10

What is perimeter?

Step 11

Measure perimeter

Step 12

Calculate perimeter



Measure in metres and centimetres

Notes and guidance

In Year 2, children used either metres or centimetres to measure the length of objects. In this small step, they revise these skills, initially using a ruler to measure objects in centimetres. They then combine both units of measurement, such as 1 m and 20 cm, for example by measuring the lengths of desks or the heights of children in the class.

Children do not need to convert between metres and centimetres at this stage, and as they have not yet been introduced to decimals, lengths should remain in the format _____ m and _____ cm.

Provide opportunities for children to use different measuring equipment, including rulers, tape measures, metre sticks and trundle wheels.

Things to look out for

- Children may measure from the end of the ruler or measuring tape rather than measuring from zero.
- When using more than one ruler to measure, children may place them end to end, rather than lining up zero with the end point of the previous ruler.
- Children may measure using the non-metric side of a ruler.

Key questions

- Where should you start measuring from on your ruler?
- What is the length of _____ in centimetres?
- What is the length of _____ in metres?
- What is the length of _____ in metres and centimetres?
- Would you measure the length of the classroom in centimetres or metres? Why?
- What equipment would you use to measure the length of _____?

Possible sentence stems

- The _____ is _____ cm long.
- The _____ is _____ m long.
- The _____ is _____ m and _____ cm long.

National Curriculum links

- Measure, compare, add and subtract: lengths (m/cm/mm); mass (kg/g); volume/capacity (l/ml)

Measure in metres and centimetres

Key learning

- What is the length of the line?

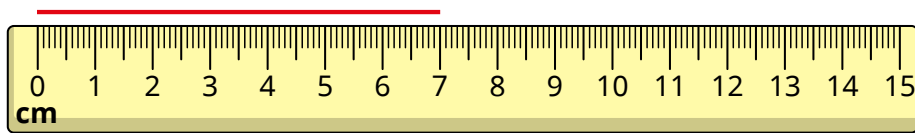

- What is the length of the lollipop?

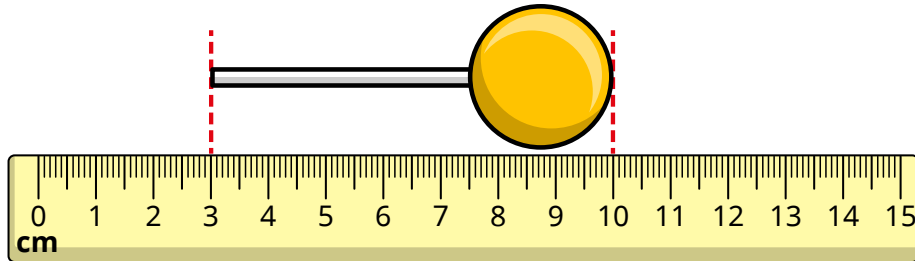

- Use a ruler to measure the lines.

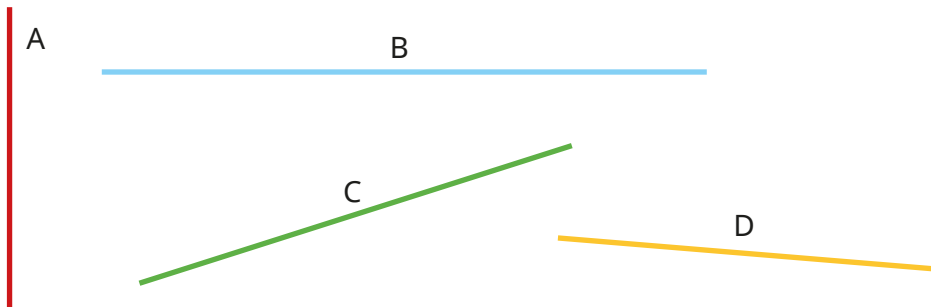

- Mo and Annie use metre sticks to measure their height. How tall are they?

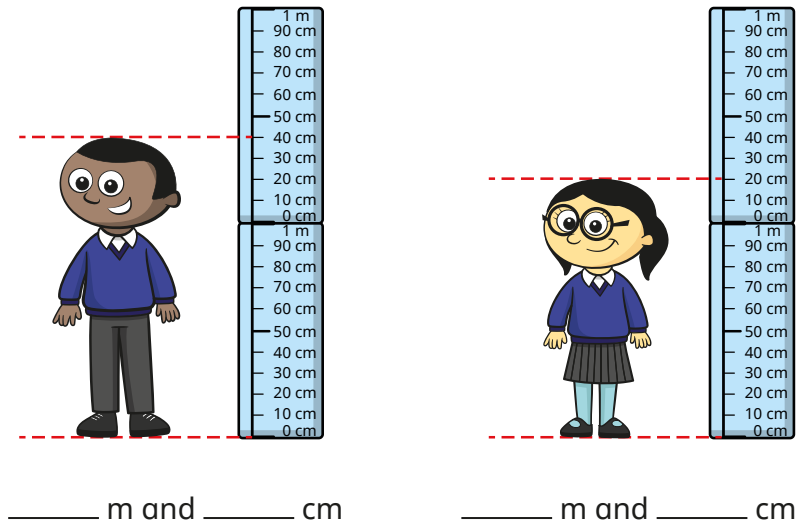

- Measure your classroom to complete the sentences.
 - The classroom is _____ m and _____ cm long.
 - The classroom is _____ m and _____ cm wide.
- ▶ Use a metre ruler to measure some other items in your classroom.
- ▶ Use a metre ruler to measure some items outside.

Measure in metres and centimetres

Reasoning and problem solving

Tiny is trying to measure the length of the line.

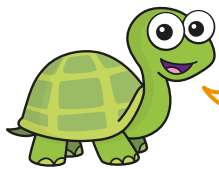
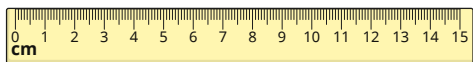

I cannot measure the line because my ruler is not long enough.

Do you agree with Tiny?

Why?



No

Dani draws a circle in chalk on the playground.

How could she measure the distance round the circle?



She could, for example, use a piece of string, wrap it round then measure the string.

Tiny is measuring the table top.

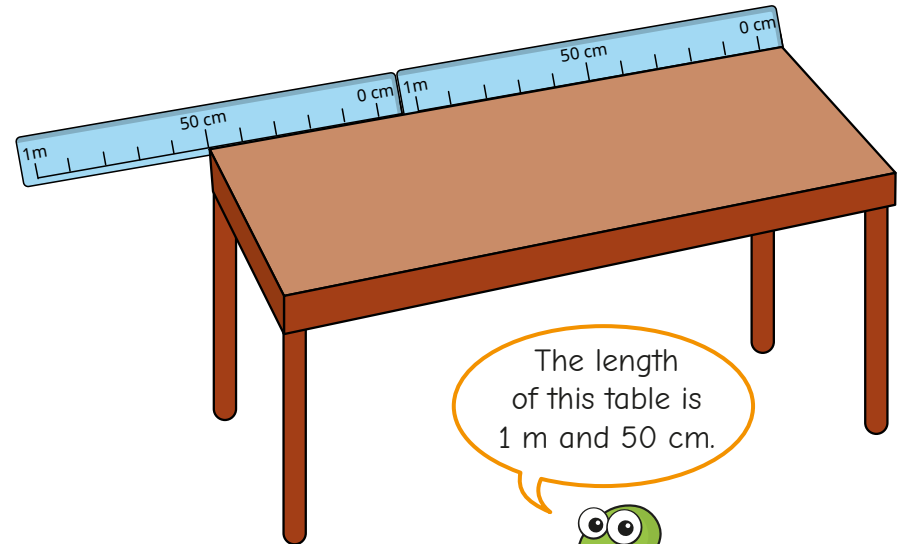

The length of this table is 1 m and 50 cm.

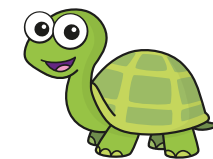

Do you agree with Tiny?

Explain your answer.



No

Measure in millimetres

Notes and guidance

This small step builds on children's understanding from the previous step by introducing millimetres as another unit of measurement.

Children need to understand that 1 mm is smaller than 1 cm and that millimetres can be used to measure lengths that are not an exact number of centimetres. Allow children time to explore a ruler with millimetre markings to see that there are 10 mm in 1 cm. Children could be encouraged to count in 10s and add on the remaining 1s when finding lengths. For example, when measuring a line that is 8 cm and 3 mm long, they can count in 10s to 80 mm and then add on the extra 3 mm to give a total length of 83 mm. However, at this stage children are not required to formally convert between centimetres and millimetres.

Children may find measuring oblique lines more difficult than horizontal or vertical lines. Model how rotating the page can make it easier to measure.

Things to look out for

- Children may measure from the end of the ruler or measuring tape rather than measuring from zero.
- Children may give answers to the nearest centimetre rather than counting the millimetre intervals.

Key questions

- Why is it important to start measuring from zero on your ruler?
- How many intervals are there between 0 and 1 cm? So how many millimetres are there in 1 cm?
- Where is the 5 mm mark on your ruler?
- What is the same and what is different about measuring a length in centimetres and measuring a length in millimetres?
- What is the length of _____ in millimetres?
- Would you measure the height of the door in millimetres?

Possible sentence stems

- The _____ is _____ mm long.
- 1 mm is _____ than 1 cm.
- 1 mm is _____ than 1 m.

National Curriculum links

- Measure, compare, add and subtract: lengths (m/cm/mm); mass (kg/g); volume/capacity (l/ml)

Measure in millimetres

Key learning

- What are the lengths of the lines in millimetres?

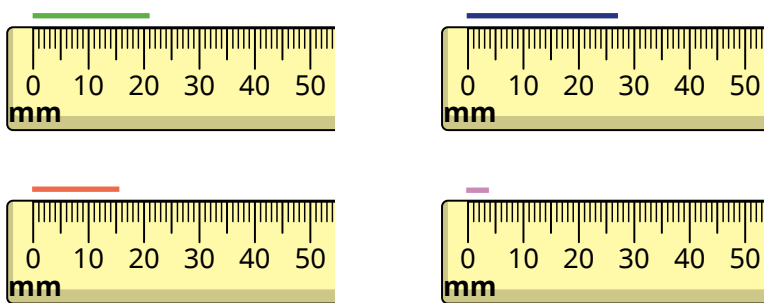

- What lengths are the arrows pointing to?

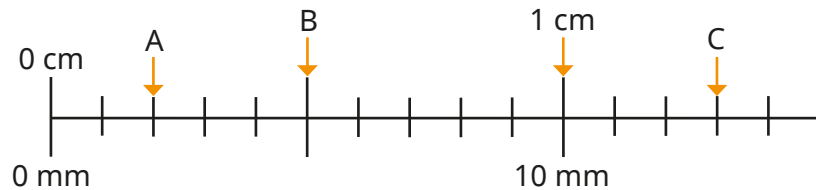

- What are the lengths of the lines in millimetres?



- Choose a phrase to complete each sentence.

less than greater than

- ▶ 1 mm is _____ 1 cm.
- ▶ 1 m is _____ 1 mm.
- Measure these lines to the nearest millimetre.

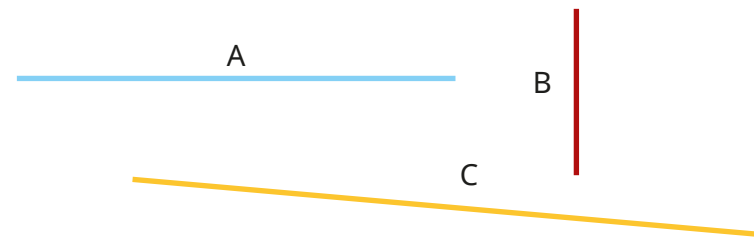

- Find five things in your pencil case that you can measure in millimetres.

List them in order of size, starting with the smallest.

- Use a ruler to draw lines with these lengths.

- ▶ 80 mm ▶ 25 mm ▶ 51 mm
- ▶ 30 mm ▶ 75 mm ▶ 67 mm

Measure in millimetres

Reasoning and problem solving

Tiny is thinking about measuring a table.

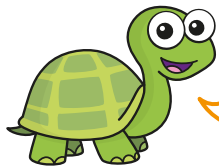

I cannot measure the table in millimetres, because it is too big.

Do you agree with Tiny?
Explain your answer.

Tiny could measure the table in millimetres, but it is not the most efficient unit to use.

Whitney measures her rubber in millimetres.

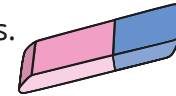

My rubber is less than 60 mm. Its length is in the 5 times-table. The digits add up to 9



Work out the length of Whitney's rubber.

45 mm

Measure these two lines in millimetres.



Which line did you find easier to measure? Why?



lines measured accurately

Is the statement true or false?

A length measured in millimetres is always shorter than a length measured in centimetres.

Talk about it with a partner.



False

Measure in centimetres and millimetres

Notes and guidance

In this small step, children combine learning from the previous steps to measure objects in centimetres and millimetres. Measurements should be recorded in the form “4 cm and 3 mm”, and encourage children to record their measurements as centimetres and millimetres, not the other way around. If possible, show children a ruler that has a centimetre scale on the top and a millimetre scale on the bottom to allow them to see the relationship between centimetres and millimetres.

If children are finding it difficult to measure using millimetre intervals, support them to identify the 5 mm interval on their ruler and count forwards or backwards. After sufficient practice, children’s measurements should be accurate to within 2 mm.

As well as measuring lengths, children also practise drawing lengths accurately.

Things to look out for

- Children may inaccurately measure the millimetre part of a length, due to the intervals on the ruler being very close together.
- Children may record a length as, for example, 5 cm and 0 mm, rather than just 5 cm.

Key questions

- Which is greater in length, 1 mm or 1 cm?
- What are the main things to remember in order to measure accurately using a ruler?
- Is the _____ an exact number of centimetres long?
- How many millimetres past the last centimetre interval does the _____ reach?
- How do you write a length that is not an exact number of centimetres?
- How does the 5 mm interval help you to measure the length?

Possible sentence stems

- _____ cm _____ mm = _____ cm and _____ mm
- The _____ is _____ cm and _____ mm long.

National Curriculum links

- Measure, compare, add and subtract: lengths (m/cm/mm); mass (kg/g); volume/capacity (l/ml)

Measure in centimetres and millimetres

Key learning

- What is the length of each object in centimetres and millimetres?

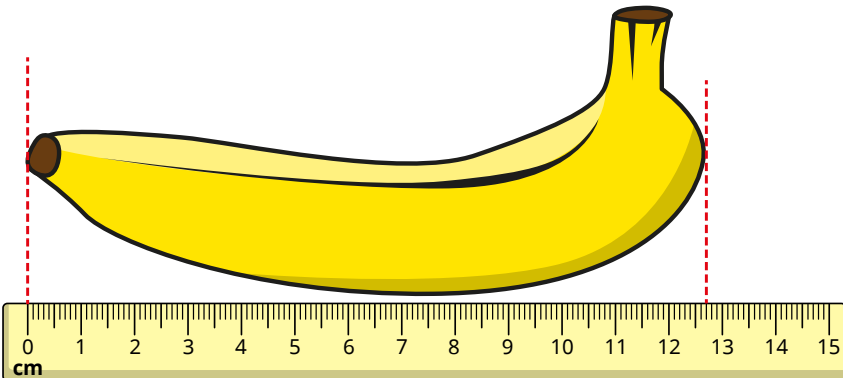
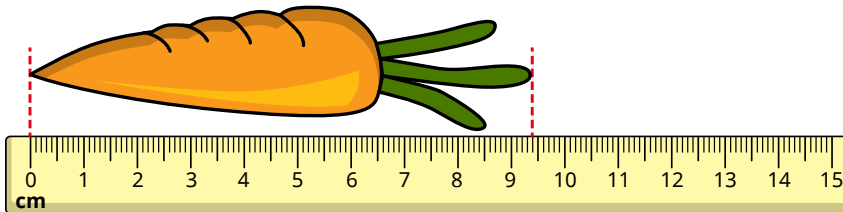

- Measure the lines.

Give your answers in centimetres and millimetres.

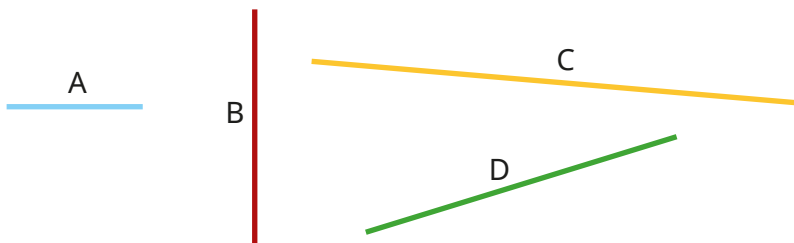

- Measure the length of some items in the classroom. Record the lengths in centimetres and millimetres. Compare answers with a partner. Are your answers exactly the same?

- Use a ruler to draw lines that measure:

- between 4 cm and 5 cm
- between 65 mm and 80 mm
- between 10 mm and 2 cm
- between 3 cm 4 mm and 3 cm 9 mm

Ask a partner to measure and label each line.

- Tiny measures the sweet.

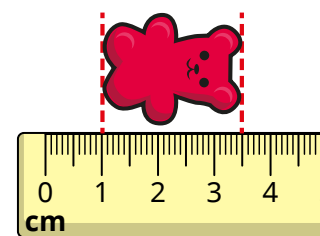

The sweet is 3 cm and 5 mm long.

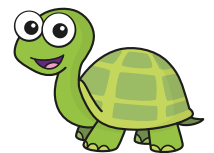

- Do you agree with Tiny?
Explain your answer.

Measure in centimetres and millimetres

Reasoning and problem solving

Dexter, Alex and Tommy are comparing the lengths of their pencils.



My pencil is 15 cm.

Dexter

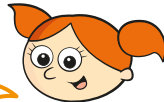

My pencil is half the length of Dexter's pencil.

Alex



My pencil is shorter than Dexter's pencil but longer than Alex's pencil.

Tommy

What could be the length of Tommy's pencil?

Compare answers with a partner.



between 7 cm and 5 mm and 14 cm and 9 mm

Four children measure the height of a carton of juice.



It is 85 mm.

Teddy

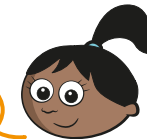

It is 8 cm and 5 mm.

Sam



It is 7 cm and 15 mm.

Annie



It is 5 mm and 8 cm.

Ron

What is the same about their measurements?

What is different?

Talk about your answer with a partner.



All the children have given the same measurement, but they have expressed it differently.

Metres, centimetres and millimetres

Notes and guidance

In this small step, children compare and consider the appropriateness of different units of measurement.

Children need to understand that although, for example, metres are used to measure longer distances, it is still possible to measure these distances in centimetres or millimetres.

Encourage discussion about why it is important to choose the appropriate unit or measuring equipment before measuring an object or length.

Children make simple comparisons of lengths that do not require them to understand equivalent units of measurement, for example, comparing 3 m with 3 cm. By this stage, however, they should know how many centimetres are in 1 m and how many millimetres are in 1 cm.

Things to look out for

- Children may focus on the number when comparing lengths, rather than considering the unit of measurement.
- Children may not have understood the relationship between millimetres, centimetres and metres.
- Children may need reminding of the meaning of the symbols $<$, $>$ and $=$.

Key questions

- How many millimetres are there in a centimetre?
- How many centimetres are there in a metre?
- Which is longer, 1 m or 1 cm?
- Which is shorter, 1 cm or 1 mm?
- Which is longer, 3 m or 60 cm?
- Which is shorter, 4 cm or 20 mm?
- What unit would you use to measure the length of _____?

Possible sentence stems

- _____ m is shorter/longer than _____ cm.
- _____ mm is shorter/longer than _____ cm.
- There are _____ mm in 1 cm.
- There are _____ cm in 1 m.

National Curriculum links

- Measure, compare, add and subtract: lengths (m/cm/mm); mass (kg/g); volume/capacity (l/ml)

Metres, centimetres and millimetres

Key learning

- Which unit would you use to measure each item?

Sort the items into the table.

length of a car	length of a pencil	
length of a fingernail	length of a garden	
length of a playground	height of a water bottle	
Metres	Centimetres	Millimetres

Compare answers with a partner.

- Write the lengths in order.

Start with the shortest length.

10 m	10 mm	10 cm
------	-------	-------

- Scott has 4 m of ribbon.

Aisha has 40 cm of ribbon.

Who has the longer piece of ribbon?

- Brett and Huan each draw a straight line.

Brett's line is 18 cm.

Huan's line is 30 mm.

Whose line is longer?

- Write $<$, $>$ or $=$ to compare the lengths.

8 cm ○ 10 mm

50 mm ○ 2 m

14 m ○ 98 cm

3 m and 87 cm ○ 4 m

6 m and 20 cm ○ 20 cm and 6 m

14 m and 5 cm ○ 14 m and 5 mm

- Write the measurements in order.

Start with the longest measurement.

2 m	87 cm	3 cm	12 mm
-----	-------	------	-------

Metres, centimetres and millimetres

Reasoning and problem solving

Use the digit cards to complete the statement.



$$1 \text{ m and } 34 \text{ cm} < \square \square \square \text{ cm} < 2 \text{ m}$$

Find all the possible answers.

135 cm, 142 cm, 143 cm, 145 cm, 152 cm, 153 cm, 154 cm



Is the statement always true, sometimes true or never true?

A length measured in metres will be longer than a length measured in centimetres.

Explain your answer.

sometimes true



Tiny is putting lengths in order.

I have put the lengths in order from shortest to longest.

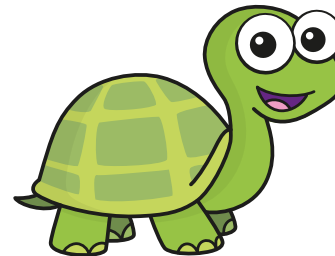

1 m 13 mm 29 cm 121 cm

What mistake has Tiny made?

Put the lengths in the correct order.



13 mm, 29 cm,
1 m, 121 cm

Equivalent lengths (metres and centimetres)

Notes and guidance

In this small step, children use the fact that 1 m is equivalent to 100 cm. They use this to convert multiples of 100 cm into metres and metres into multiples of 100 cm. At the beginning of this step, it might be helpful to practise counting in 100s as a class.

Encourage children to partition the measurement into metres and centimetres when converting lengths that are not multiples of 100, for example $134 \text{ cm} = 1 \text{ m}$ and 34 cm . Part-whole models, bar models and double number lines are useful representations to support children in these conversions.

Children may also be encouraged to find and use common fractions to convert between metres and centimetres, for example $\frac{1}{2} \text{ m}$ is equivalent to 50 cm , so $4\frac{1}{2} \text{ m}$ is equivalent to 450 cm .

Things to look out for

- Children may partition centimetres according to place value, which is inefficient when converting centimetres into metres. For example, $163 \text{ cm} = 100 \text{ cm} + 60 \text{ cm} + 3 \text{ cm}$ rather than $100 \text{ cm} + 63 \text{ cm}$.
- When converting multiples of 100 cm, such as 400 cm, children may write 4 m and 0 cm.

Key questions

- How many centimetres are there in 1 m?
- How can you work out how many centimetres there are in 6 m?
- What is _____ centimetres in metres?
- How many centimetres are there in _____ m and _____ cm?
- How can you partition 430 cm to help you to write the measurement in metres and centimetres?
- How many centimetres are there in $\frac{1}{2} \text{ m}$?
So how many centimetres are there in $4\frac{1}{2} \text{ metres}$?

Possible sentence stems

- There are _____ cm in 1 m.
- $1 \text{ m} = 100 \text{ cm}$, so _____ m = _____ cm
- I can partition _____ cm into _____ cm and _____ cm.
- There are 100 cm in 1 m, so _____ cm = _____ m and _____ cm.
- $\frac{1}{2} \text{ m} =$ _____ cm

National Curriculum links

- Measure, compare, add and subtract: lengths (m/cm/mm); mass (kg/g); volume/capacity (l/ml)

Equivalent lengths (metres and centimetres)

Key learning

- Use the bar models to complete the sentences.

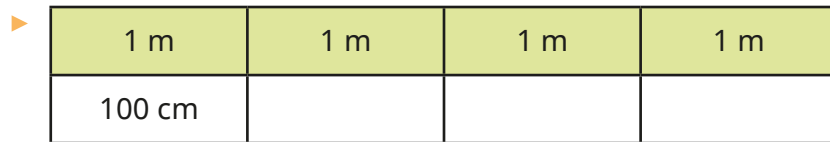

4 m = _____ cm

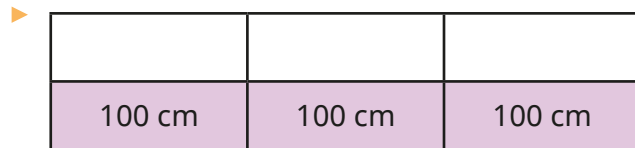

_____ m = 300 cm

- Esther uses a part-whole model to find equivalent lengths.

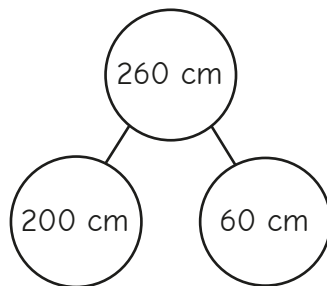

200 cm = 2 m
260 cm = 2 m and 60 cm

Use Esther's method to convert the lengths into metres and centimetres.

120 cm	125 cm	367 cm	542 cm
--------	--------	--------	--------

- Where do the measurements belong on the measuring stick?

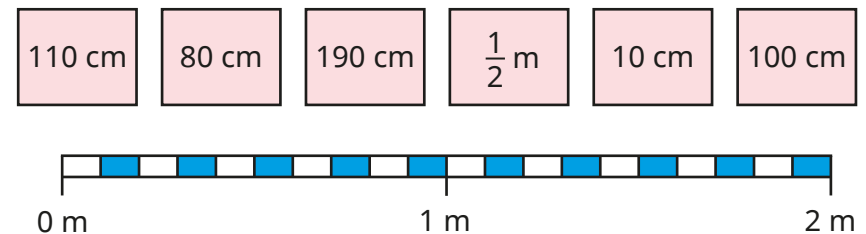

- Complete the bar models.

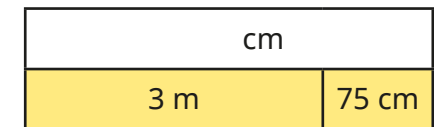
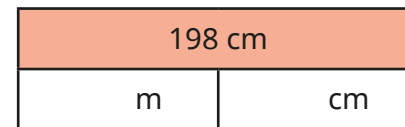
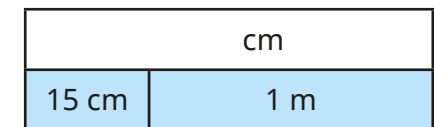
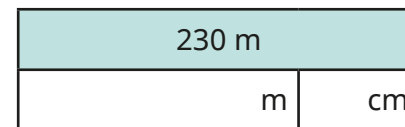

- Complete the sentences.
 - ▶ 3 m and 52 cm = _____ cm
 - ▶ 2 m and 19 cm = _____ cm
 - ▶ 483 cm = _____ m and _____ cm
 - ▶ 501 cm = _____ m and _____ cm

Equivalent lengths (metres and centimetres)

Reasoning and problem solving

Is the statement true or false?

$$413 \text{ cm} > 4 \text{ m and } 31 \text{ cm}$$

False

Explain your answer.



Which measurement is the odd one out?

250 cm

25 cm

$2\frac{1}{2}$ m

2 m 50 cm

25 cm

Explain your choice.



Eva and Jack each have a skipping rope.

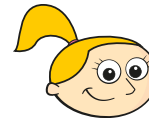

Eva

I have the longer skipping rope.
My skipping rope is $2\frac{1}{2}$ m long.

My skipping rope is 220 cm. It is longer than Eva's because 220 is greater than $2\frac{1}{2}$



Jack

Eva

Her skipping rope is 250 cm long, which is 30 cm longer than 220 cm.

Who is correct?

Explain your answer.

Equivalent lengths (centimetres and millimetres)

Notes and guidance

In this small step, children use the fact that 1 cm is equivalent to 10 mm. They use this to convert millimetres into centimetres and centimetres into millimetres. Recapping previous knowledge of multiples of 10 from Spring Block 1 may be useful prior to teaching this new content.

As children have not yet formally explored multiplying and dividing by 10, they should be encouraged to partition measurements into centimetres and millimetres when converting lengths that are not multiples of 10, for example $34 \text{ mm} = 30 \text{ mm} + 4 \text{ mm} = 3 \text{ cm and } 4 \text{ mm}$.

As in previous steps, children do not need to use decimal notation in this step. Bar models, part-whole models and double number lines are also useful representations to explore the connection between units of measurement.

Things to look out for

- Once a length has been partitioned, children may convert the incorrect part, for example $52 \text{ mm} = 2 \text{ cm and } 5 \text{ mm}$.
- Children may convert centimetres to millimetres, but then forget to add on the remaining millimetres, for example $6 \text{ cm } 7 \text{ mm} = 60 \text{ mm}$.

Key questions

- How many millimetres are there in 1 cm?
- How can you work out how many millimetres there are in 4 cm?
- How many millimetres are there in _____ cm and _____ mm?
- How do you know _____ mm and _____ cm are equivalent?
- How can you partition 47 mm to help you convert into centimetres and millimetres?
- How many millimetres are there in $\frac{1}{2}$ cm?

Possible sentence stems

- 1 cm = 10 mm, so _____ mm = _____ cm
- 1 cm = 10 mm, so _____ cm = _____ mm
- _____ mm = _____ mm + _____ mm = _____ cm and _____ mm
- _____ cm and _____ mm = _____ mm + _____ mm = _____ mm

National Curriculum links

- Measure, compare, add and subtract: lengths (m/cm/mm); mass (kg/g); volume/capacity (l/ml)

Equivalent lengths (centimetres and millimetres)

Key learning

- Use the bar models to complete the sentences.

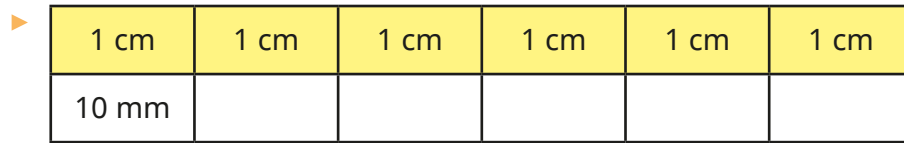

6 cm = _____ mm

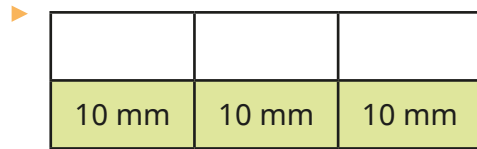

30 mm = _____ cm

- What measurements are the arrows pointing to?

Complete the sentences.

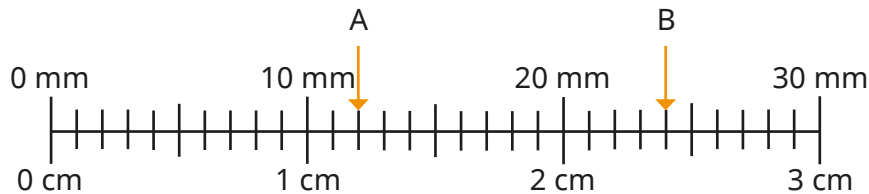

▶ A = _____ cm and _____ mm

A = _____ mm

▶ B = _____ cm and _____ mm

B = _____ mm

- Whitney uses a part-whole model to find an equivalent length.

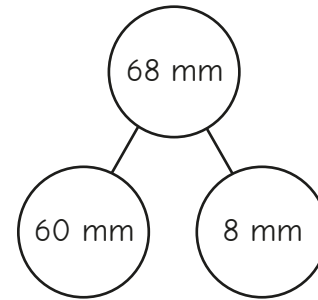

60 mm = 6 cm
68 mm = 6 cm and 8 mm

Use Whitney's method to convert the lengths into centimetres and millimetres.

- ▶ 24 mm ▶ 35 mm ▶ 91 mm ▶ 88 mm

- Ron uses a part-whole model to find an equivalent length.

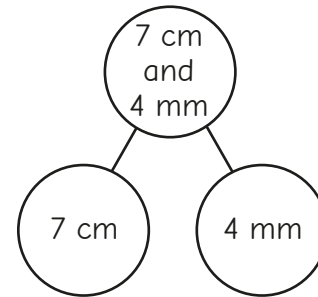

7 cm = 70 mm
7 cm and 4 mm = 74 mm

Use Ron's method to convert the lengths into millimetres.

- ▶ 6 cm and 8 mm ▶ 8 cm and 6 mm ▶ 1 cm and 9 mm

Equivalent lengths (centimetres and millimetres)

Reasoning and problem solving

Mo, Rosie and Kim are finding equivalent lengths.



40 cm and 7 mm is equivalent to 47 mm.

Mo

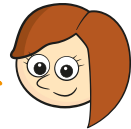

4 cm and 7 mm is equivalent to 47 mm.

Rosie



7 mm and 4 cm is equivalent to 47 mm.

Kim

Whose conversion is incorrect?

Whose conversion could be improved?

Talk about your answers with a partner.



Mo

Kim

Dexter is thinking of a measurement.



In millimetres, my measurement is a multiple of 2
It is greater than 81 mm.
It can be partitioned as 8 cm and _____ mm.

82 mm, 84 mm,
86 mm or 88 mm

What measurement could Dexter be thinking of?

Which measurement is the odd one out?

500 mm

50 cm

$\frac{1}{2}$ m

500 cm

500 cm

Explain your choice.



Compare lengths

Notes and guidance

In this small step, children compare and order lengths using comparison language and inequality symbols. Building on the previous two steps, they need to convert all the measurements to the same unit of length before comparing.

Children can use practical equipment to justify decisions, measuring and comparing lengths of objects inside and outside the classroom to practise their measuring skills.

Children may need reminding of the meaning of the inequality symbols, $<$ and $>$. Recapping how many millimetres are in a centimetre and how many centimetres are in a metre will also be useful.

Ensure children are aware that while they use the words shorter/longer when comparing lengths, they should use shorter/taller when talking about height.

Things to look out for

- If children attempt to compare lengths without converting into the same unit of measurement, they may make mistakes.
- Children need very secure place value understanding when comparing a length in metres with a length in millimetres.

Key questions

- How can you compare lengths given in different units?
- Why does finding equivalent lengths with the same unit make it easier to compare lengths?
- Does it matter which unit of measurement you use to compare?
- Is the unit of measurement or the size of the number more important?
- How many mm/cm are there in _____ cm/m?

Possible sentence stems

- _____ m _____ cm is equal to _____ cm.
- _____ cm is _____ than _____ cm, so the greater length is _____ cm.
- _____ cm is equal to _____ mm.
- _____ mm is _____ than _____ mm, so the greater length is _____ mm.

National Curriculum links

- Measure, compare, add and subtract: lengths (m/cm/mm); mass (kg/g); volume/capacity (l/ml)

Compare lengths

Key learning

- Jack is comparing 34 mm and 3 cm 6 mm.

Complete the sentences.

- ▶ 3 cm 6 mm = _____ mm
- ▶ 34 mm is _____ than _____ mm.

Is there another way to compare the measurements?

- Amir and Dora measure their heights.
 - Amir's height is 127 cm.
 - Dora's height is 1 m and 30 cm.

Write **taller** or **shorter** to complete the sentences.

- ▶ Amir is _____ than Dora.
- ▶ Dora is _____ than Amir.

- Write $<$, $>$ or $=$ to compare the lengths.

101 cm ○ 1 m 10 cm

80 mm ○ 8 cm

90 cm ○ 90 mm

500 mm ○ 1 m 50 cm

- Write the lengths in order.

Start with the shortest length.

230 cm	750 mm	2 m 25 cm
2 m	1 m 75 cm	170 cm

- Fill in the missing numbers to make the statements correct.
 - ▶ 4 cm $<$ _____ mm
 - ▶ _____ m $<$ 378 cm
 - ▶ 245 mm = _____ cm + _____ mm
 - ▶ 5 m $>$ _____ m and 99 cm
- Four friends are building towers.
 - Filip's tower is 22 cm and 7 mm tall.
 - Tom's tower is 22 cm tall.
 - Nijah's tower is 215 mm tall.
 - Dani's tower is 260 mm tall.

Complete the statement to put the towers in height order.

_____ $<$ _____ $<$ _____ $<$ _____

Compare lengths

Reasoning and problem solving

Brett has put some lengths in order from shortest to longest.



170 mm

74 cm 7 mm

$1\frac{1}{2}$ m

Fill in the missing measurement.
Find three possible answers.



between
74 cm 8 mm and
1 m 49 cm

Sort the lengths into the table.

1 m 65 cm	165 mm
165 m	165 cm
160 cm 5 mm	16 cm 5 mm

Longer than a metre	Shorter than a metre

Are any of the lengths equivalent?

longer than a metre:
1 m 65 cm, 165 m,
165 cm,
160 cm 5 mm

shorter than a metre:
165 mm,
16 cm 5 mm

equivalent lengths:
1 m 65 cm and
165 cm
165 mm and
16 cm 5 mm

Add lengths

Notes and guidance

In this small step, children add lengths. They begin by adding lengths that are measured in the same unit of measurement, before adding lengths that have different units.

When measurements have different units, children should find equivalent lengths with the same unit to allow them to add the two lengths. It is important to explore with children that this can be done in two ways, for example $38\text{ mm} + 2\text{ cm}$ could be added as $38\text{ mm} + 20\text{ mm}$ or as $3\text{ cm} + 8\text{ mm} + 2\text{ cm}$. Encourage children to discuss the different strategies available when adding lengths, before choosing the most efficient method.

This step provides an opportunity to revisit addition both with and without exchanges as covered in Autumn Block 2

Children will use skills learnt in this step when adding lengths to find the perimeter later in the block.

Things to look out for

- If children are not secure with converting units of measurement, they may make errors when adding lengths.
- Children may add lengths without converting the units of measurement, for example $14\text{ cm} + 24\text{ mm} = 38\text{ cm}$.

Key questions

- How many centimetres are there in 1 m?
- How many millimetres are there in 1 cm?
- Why is it important the lengths have the same unit of measurement before adding them?
- Which unit of measurement will you use to find equivalent lengths before adding them? Why?
- How did you find the total length?
- Does it matter in which order you add the lengths?

Possible sentence stems

- _____ cm + _____ mm = _____ mm + _____ mm = _____ mm
- _____ m + _____ cm = _____ cm + _____ cm = _____ cm
- I am going to convert all of the units of measurement to _____ because ...

National Curriculum links

- Measure, compare, add and subtract: lengths (m/cm/mm); mass (kg/g); volume/capacity (l/ml)

Add lengths

Key learning

- Dora builds this tower out of boxes.

▶ How tall is Dora's tower?

Dora puts a third box on the tower.

The box is 30 cm tall.

▶ How tall is Dora's tower now?

Can you write your answer another way?

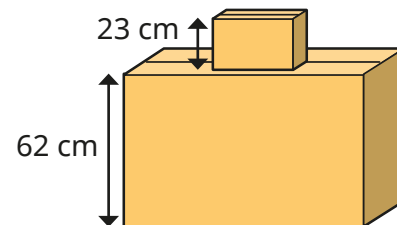

- Teddy and Kim are working out $350\text{ cm} + 1\text{ m } 20\text{ cm}$.

Teddy's method

$$350\text{ cm} + 1\text{ m } 20\text{ cm}$$

$$350\text{ cm} + 120\text{ cm} = 470\text{ cm}$$

Kim's method

$$350\text{ cm} + 1\text{ m } 20\text{ cm}$$

$$3\text{ m } 50\text{ cm} + 1\text{ m } 20\text{ cm}$$

$$3\text{ m} + 1\text{ m} = 4\text{ m}$$

$$50\text{ cm} + 20\text{ cm} = 70\text{ cm}$$

$$4\text{ m and } 70\text{ cm}$$

Talk about their methods with a partner.

Use both methods to work out the additions.

$$3\text{ m } 65\text{ cm} + 240\text{ cm}$$

$$135\text{ cm} + 5\text{ m and } 20\text{ cm}$$

- Complete the additions.

▶ $7\text{ cm} + 30\text{ mm} = 7\text{ cm} + \underline{\hspace{1cm}}\text{ cm} = \underline{\hspace{1cm}}\text{ cm}$

▶ $22\text{ mm} + 4\text{ cm} = 22\text{ mm} + \underline{\hspace{1cm}}\text{ mm} = \underline{\hspace{1cm}}\text{ mm}$

▶ $\underline{\hspace{1cm}}\text{ cm} = \frac{1}{2}\text{ m} + 28\text{ cm}$

- Complete the bar models.

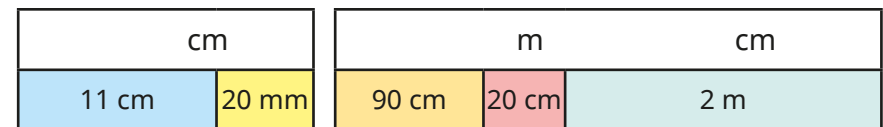

- Sam, Ron and Esther take part in a standing jump competition.

Complete the table to show their total jump distances.

Child	Jump 1	Jump 2	Jump 3	Total
Sam	90 cm	65 cm	1 m 10 cm	
Ron	85 cm	85 cm	80 cm	
Esther	75 cm	1 m	1 m 25 cm	

Who jumped the greatest total distance?

Add lengths

Reasoning and problem solving

Red cubes are 30 mm tall.
Green cuboids are 4 cm tall.

Tommy builds these towers.

Work out the height of each tower.

Give your answer in centimetres and in millimetres.

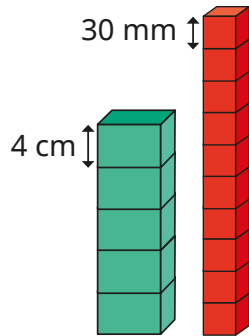

How much taller is the red tower than the green tower?

Draw a tower of red cubes that is between 12 cm and 24 cm tall.

Draw a tower of green cuboids that is between 12 cm and 24 cm tall.

How many answers can you find?

green tower:
20 cm, 200 mm
red tower:
30 cm, 300 mm

10 cm, 100 mm

4 to 8 red cubes
3 to 6 green cuboids

Work out the missing length.

$$234 \text{ cm} + 1 \text{ m } 83 \text{ cm} = 2 \text{ m} + \square \text{ cm}$$

217 cm

Compare methods with a partner.

Which is the odd one out?

$$4 \text{ m} + 30 \text{ cm} + 70 \text{ cm}$$

$$245 \text{ cm} + 255 \text{ cm}$$

$$50 \text{ mm} + 4 \text{ m} + 95 \text{ cm}$$

$$3\frac{1}{2} \text{ m} + 1\frac{1}{2} \text{ m}$$

All calculations add up to 5 m.

Possible answers may refer to units of measurement, fractions, number of digits.

Explain your choice.

Subtract lengths

Notes and guidance

In this small step, children begin by subtracting lengths that are measured in the same unit of measurement. They then look at subtracting millimetres from a whole number of centimetres as well as centimetres from a whole number of metres using simple conversions, for example $1\text{ m} - 35\text{ cm}$ and $4\text{ cm} - 3\text{ mm}$. They then explore more complex examples where the lengths have different units of measurement and therefore equivalent lengths need to be found, for example $4\text{ m } 36\text{ cm} - 112\text{ cm}$. This can be a useful opportunity to also revisit subtraction where there is a need for exchange, for example $2\text{ m } 43\text{ cm} - 118\text{ cm}$.

Children should be exposed to the different structures of subtraction through word problems: partitioning, reduction and difference. Bar models can be a useful pictorial representation to highlight these different structures.

Things to look out for

- If children are not secure with converting between units of measurement, they may make errors when subtracting lengths.
- Children may subtract lengths without converting the units of measurement, for example $71\text{ cm} - 5\text{ mm} = 66\text{ cm}$.

Key questions

- How many centimetres are there in _____ m and _____ cm?
- Why is it important that the lengths have the same unit of measurement before you subtract them?
- Which unit of measurement will you use to find equivalent lengths before you subtract them? Why?
- What is the difference in length between the two objects?
- How can you check that you have the correct answer?

Possible sentence stems

- _____ mm/cm = 1 cm/1 m
- _____ cm – _____ mm = _____ mm – _____ mm = _____ mm
- _____ m – _____ cm = _____ cm – _____ cm = _____ cm
- I am going to convert all of the units of measurement to _____ because ...

National Curriculum links

- Measure, compare, add and subtract: lengths (m/cm/mm); mass (kg/g); volume/capacity (l/ml)

Subtract lengths

Key learning

- Complete the bar models.

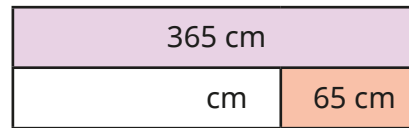
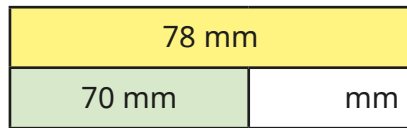

- What is the difference in length between the bottle of water and the can of fizzy drink?

Write your answer in centimetres.

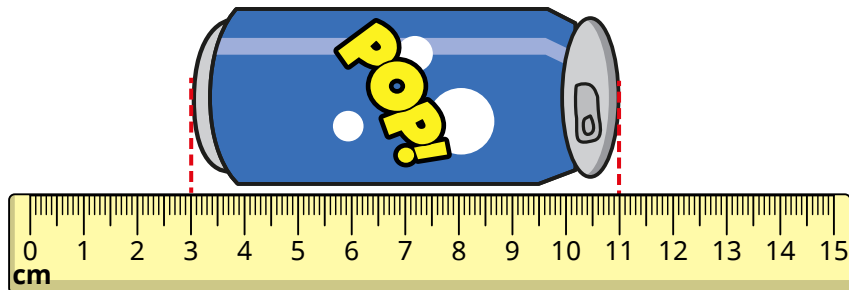
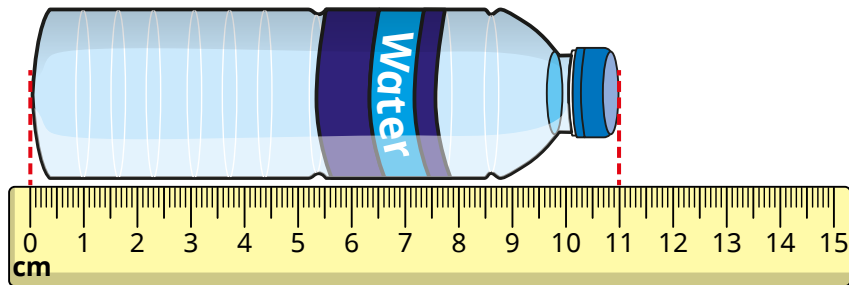

- Complete the subtractions.

- ▶ $1\text{ m} - 42\text{ cm} = \underline{\hspace{2cm}}\text{ cm}$
- ▶ $5\text{ cm} - 3\text{ mm} = \underline{\hspace{2cm}}\text{ mm}$
- ▶ $3\text{ m} - 42\text{ cm} = \underline{\hspace{1cm}}\text{ m } \underline{\hspace{1cm}}\text{ cm}$
- ▶ $88\text{ mm} = 10\text{ cm} - \underline{\hspace{2cm}}\text{ mm}$

- Tommy and Eva are working out $3\text{ m } 85\text{ cm} - 120\text{ cm}$. Here are their workings.

Tommy's method

$$\begin{aligned}
 3\text{ m } 85\text{ cm} - 120\text{ cm} \\
 120\text{ cm} &= 1\text{ m } 20\text{ cm} \\
 3\text{ m} - 1\text{ m} &= 2\text{ m} \\
 85\text{ cm} - 20\text{ cm} &= 65\text{ cm} \\
 3\text{ m } 85\text{ cm} - 120\text{ cm} &= 2\text{ m } 65\text{ cm}
 \end{aligned}$$

Eva's method

$$\begin{aligned}
 3\text{ m } 85\text{ cm} - 120\text{ cm} \\
 3\text{ m} &= 300\text{ cm} \\
 3\text{ m } 85\text{ cm} &= 385\text{ cm} \\
 385\text{ cm} - 120\text{ cm} &= 265\text{ cm} \\
 3\text{ m } 85\text{ cm} - 120\text{ cm} &= 265\text{ cm}
 \end{aligned}$$

Whose method do you prefer?

- Kim has 5 m of rope. She uses 1 m and 54 cm to make a skipping rope. How much rope does she have left?

Subtract lengths

Reasoning and problem solving

A bike race is 950 m long.

Dora cycles 243 m and stops for a break.

She cycles another 459 m and stops for another break.

How much further does she need to cycle to complete the race?



248 m

A train engine is 20 metres long.

A car is $15\frac{1}{2}$ m shorter than the train.

A bike is 250 cm shorter than the car.

Work out the length of the car.

Work out the length of the bike.

How much longer is the train than the bike?



$4\frac{1}{2}$ m

200 cm or 2 m

18 m

Tom has a 3 m roll of ribbon.

He is cutting it up into 10 cm lengths.

How many lengths can he cut?



Tom gives 240 cm of his ribbon to Nijah.

How much ribbon does he have left?

How many 10 cm lengths does Tom have left?

30

60 cm, 6 lengths



Tiny has worked out
 $3\text{ m }20\text{ cm} - 2\text{ m }56\text{ cm}$.

$$\begin{array}{r} 3\text{ m }20\text{ cm} - 2\text{ m }56\text{ cm} \\ = 1\text{ m }36\text{ cm} \end{array}$$

What mistake has Tiny made?

What is the correct answer?



64 cm

What is perimeter?

Notes and guidance

In this small step, children are introduced to perimeter for the first time.

Children learn that perimeter is the distance around the outside of a closed 2-D shape. Children explore what perimeter is, and what it is not, by deciding whether they can find the perimeter of a group of open and closed 2-D shapes.

Provide children with practical opportunities to understand perimeter, such as walking around the perimeter of the playground or using their finger to trace the perimeter of 2-D shapes.

At the end of this step, children start to find the perimeter of shapes on squared grids by counting along the edges. Encourage children to mark as they count to ensure they do not miscount.

Things to look out for

- Children may think that it is possible to find the perimeter of open shapes.
- When children are finding the perimeter of a shape on a squared grid, they may miscount by counting all of the squares around the shape rather than along the edge of the shape.
- Children may trace or count some sides more than once.

Key questions

- What does “perimeter” mean?
- When might someone need to find the perimeter in real life?
- Why are you unable to find the perimeter of this shape?
- How would you use your finger to trace the perimeter of this piece of paper?
- Which of the shapes has the greater perimeter?
How do you know?
- How does the squared grid help you to find the perimeter?

Possible sentence stems

- The perimeter of a shape is ...
- This shape does/does not have a perimeter because ...
- I can find the perimeter of this shape by ...

National Curriculum links

- Measure, compare, add and subtract: lengths (m/cm/mm); mass (kg/g); volume/capacity (l/ml)
- Measure the perimeter of simple 2-D shapes

What is perimeter?

Key learning

- Which shapes have a perimeter?

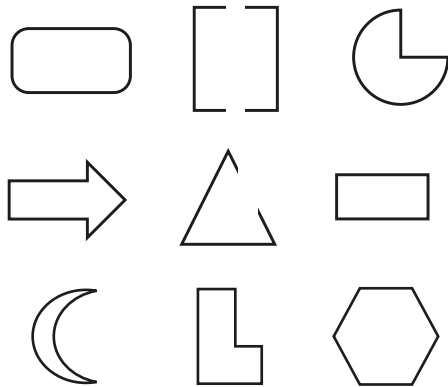

Why do some of the shapes not have a perimeter?

Compare answers with a partner.

- Which shape has the greater perimeter in each pair?

How do you know?

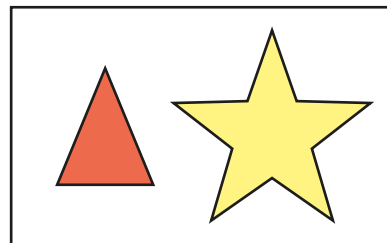
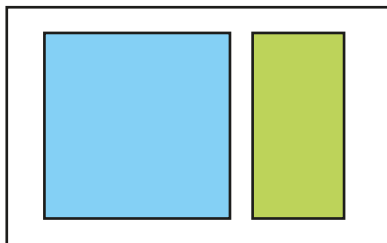

- Scott counts around the edge of the rectangle to find the perimeter.

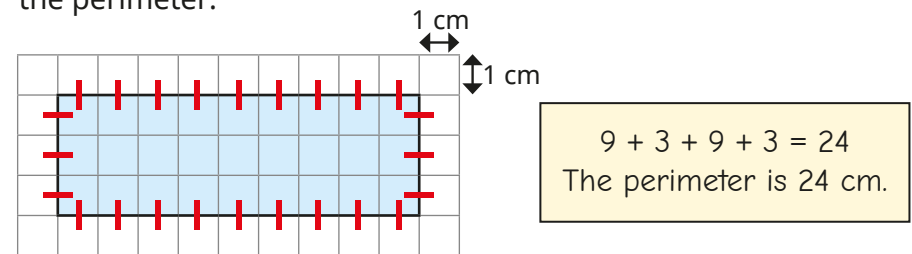

Use Scott's method to find the perimeter of each rectangle.

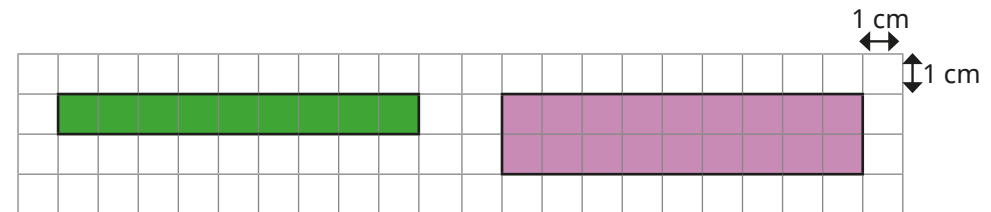

What do you notice?

- Work out the perimeters of the shapes.

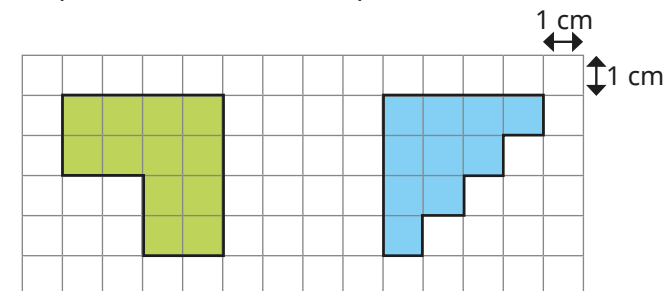

What is perimeter?

Reasoning and problem solving

Whitney wants to find the perimeter of this shape.

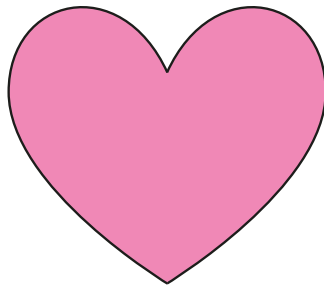

I cannot find the perimeter of the shape, because it does not have straight sides.



Do you agree with Whitney?
Explain your thinking.

No

Tiny is finding the perimeter of the shape by counting squares.

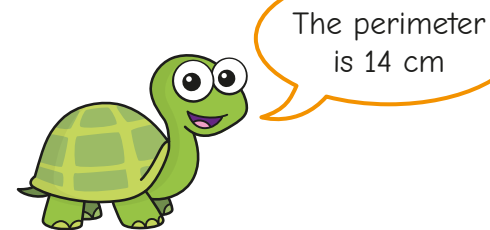
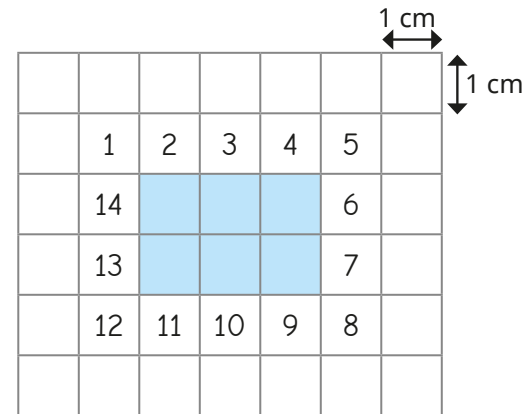

The perimeter is 14 cm

What mistake has Tiny made?
Find the correct perimeter.

Tiny has counted the squares rather than the edges of the shape.

10 cm

Measure perimeter

Notes and guidance

In this small step, children measure the sides of different shapes in centimetres to find the perimeter. This builds on the previous step, where children found the perimeter by counting the number of squares of each length.

Encourage children to work in a systematic order, possibly marking the lengths after they have been measured, to ensure that children measure the lengths of all the sides.

Children should also be encouraged to think about whether it is necessary to measure every side to find the perimeter or whether they can use the properties of 2-D shapes to help them.

Children could explore measuring the perimeter of shapes with curved sides by using a piece of wool or string to place along the edges and then measuring the wool or string with a ruler.

Things to look out for

- When measuring, children may start from the beginning of the ruler, rather than from the zero mark.
- Children may not record the units of measurement in their answer.
- Children may measure using the non-metric side of the ruler.

Key questions

- What does “perimeter” mean?
- What equipment is useful for measuring the perimeter of a shape?
- Does starting in different places when measuring the perimeter give you a different answer?
- Do you need to measure all the sides? How do you know?
- How do you know that you have measured all the sides?
- Which method do you prefer, to find the perimeter of a square?
- Can you find the perimeter of a shape with a curved edge? How?

Possible sentence stems

- Perimeter is ...
- _____ cm + _____ cm + _____ cm + _____ cm = _____ cm

National Curriculum links

- Measure, compare, add and subtract: lengths (m/cm/mm); mass (kg/g); volume/capacity (l/ml)
- Measure the perimeter of simple 2-D shapes

Measure perimeter

Key learning

- Measure and label each side of the rectangle.



What is the perimeter of the rectangle?

_____ + _____ + _____ + _____ = _____ cm

- Measure and label the sides on each shape.

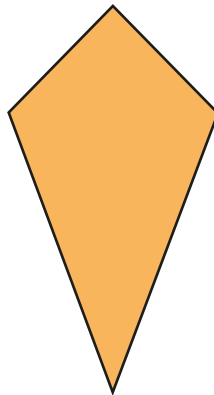
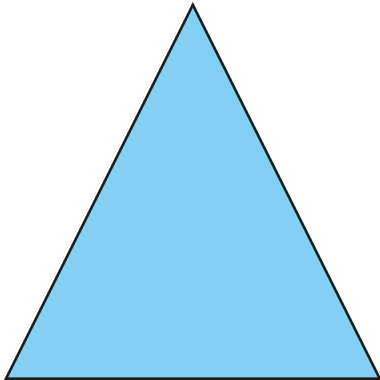

Work out the perimeter of each shape.

- Measure and label the sides of the hexagons.

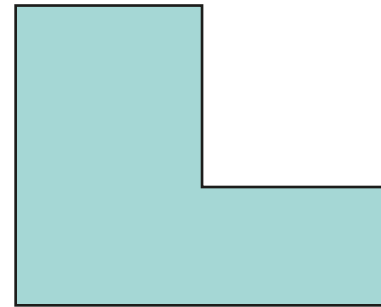

Work out the perimeter of each hexagon.

- Here is a square.

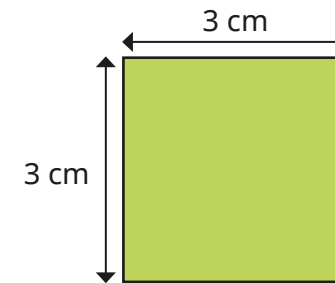

Do you need to measure all the sides to find the perimeter?

What is the perimeter of the square?

Measure perimeter

Reasoning and problem solving

Scott is measuring the perimeter of a rectangle.



Scott only needs to measure two sides!

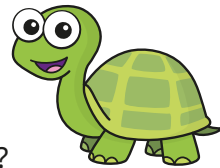

Do you agree with Tiny?

Explain your answer.



Yes

Dexter thinks that the perimeter of the triangle is 17 cm.

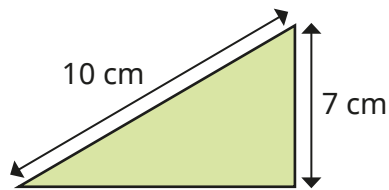

Explain why Dexter is incorrect.

Dexter has only measured two sides of the triangle.

The perimeter is the total distance around the shape.

Sam measures the sides to find the perimeters of the shapes.

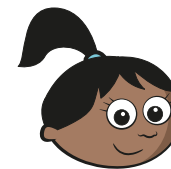
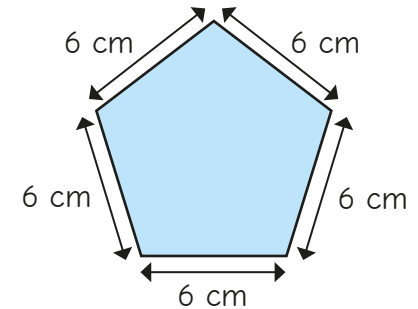
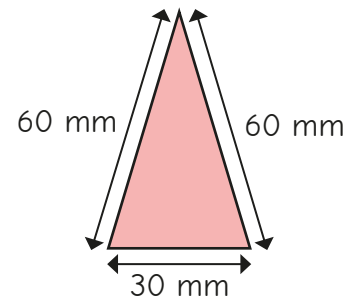

The perimeter of the triangle is greater than the perimeter of the pentagon.

What mistake has Sam made?

The units of measurement are different.
triangle = 15 cm; pentagon = 30 cm

Calculate perimeter

Notes and guidance

In this small step, children use their understanding of the properties of different shapes to calculate the perimeter of simple 2-D shapes.

Encourage children to identify equal sides of a square and equal opposite sides of a rectangle to support them in calculating the perimeter. It is important to explore different strategies for calculating perimeter with children and encourage them to use more efficient strategies, for example for a rectangle they could add all four lengths, they could double the width and length and add them together or they could add the width and length and then double.

Although children can calculate the perimeter of rectilinear shapes in this step, these shapes are not formally introduced until Year 4

Things to look out for

- Children may not record the units of measurement in their answer.
- Children may not remember that a square has four equal sides and that opposite sides of a rectangle are equal.
- Children may find it difficult to add lengths measured in centimetres and millimetres.

Key questions

- Are any of the sides equal?
- How can you work out the perimeter of the shape?
- What other method could you use to find the perimeter of the shape?
- How can you work out the lengths of the sides that are not labelled?
- How many sides do you need to measure before you can find the perimeter?
- Do the lengths need to have the same unit of measurement? How do you find equivalent lengths?

Possible sentence stems

- Opposite sides of a rectangle are _____
- The missing side length is _____ cm because ...

National Curriculum links

- Measure, compare, add and subtract: lengths (m/cm/mm); mass (kg/g); volume/capacity (l/ml)
- Measure the perimeter of simple 2-D shapes

Calculate perimeter

Key learning

- Find the perimeters of the rectangles.

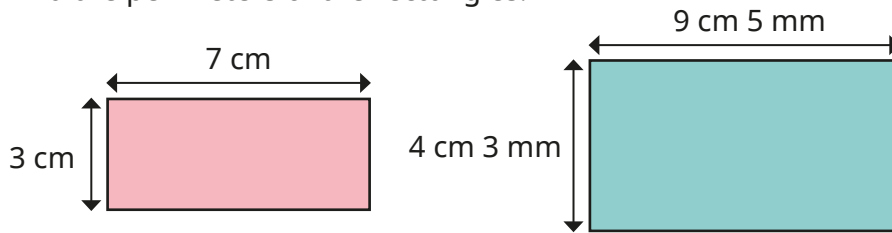

Compare methods with a partner.

- Find the perimeter of the square.

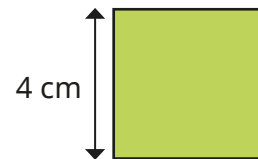

- Work out the perimeter of each shape.

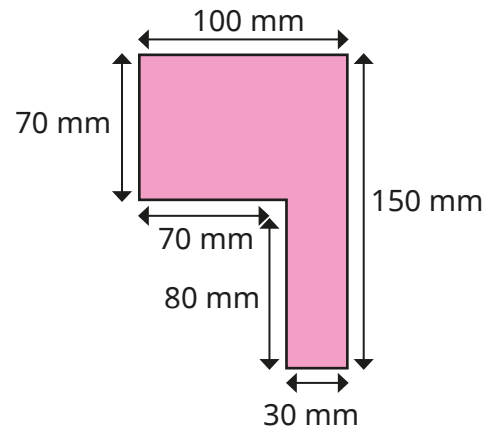
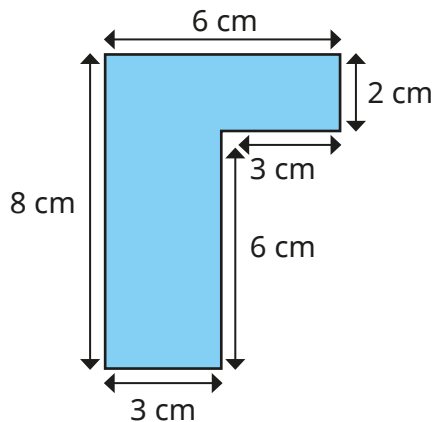

- Find the unknown lengths.

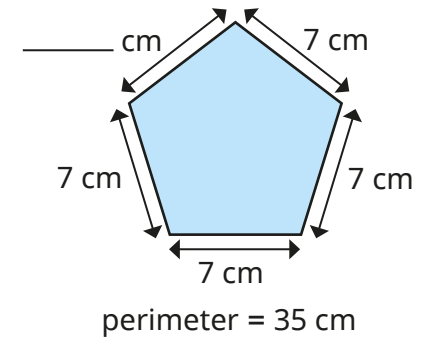
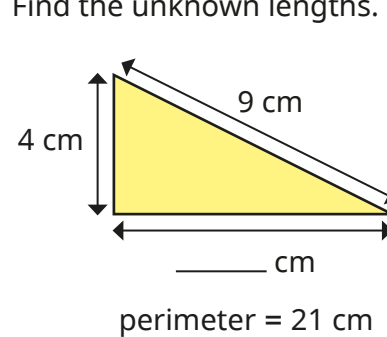

- Esther is finding the unknown length of the rectangle.

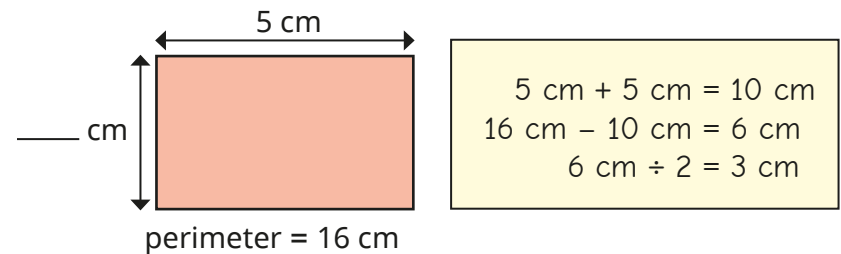

Use Esther's method to find the unknown length.

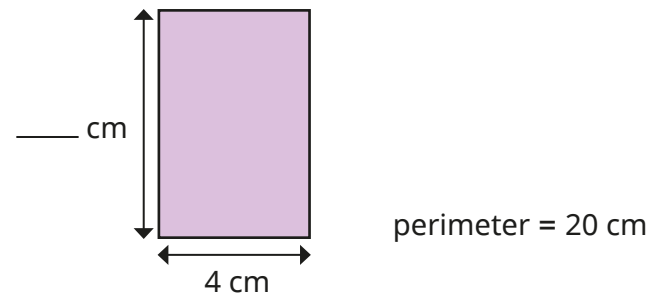

Calculate perimeter

Reasoning and problem solving

How many sides do you need to measure to find the perimeter of each shape?

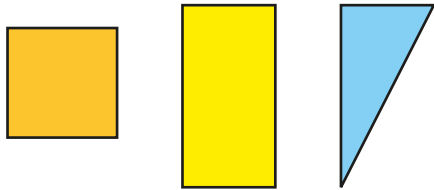

Explain your answers.



square: one side
rectangle: two adjacent sides
triangle: all three sides

Each side of this shape is the same length.



The perimeter is 60 cm.
How long is each side?



6 cm

The rectangle and square have the same perimeter.

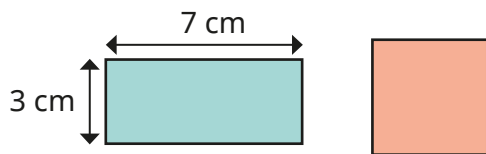

What is the length of each side of the square?



5 cm

The perimeter of the square is greater than 11 cm and less than 25 cm.



In whole centimetres, what could the length of one side be?



3 cm, 4 cm, 5 cm or 6 cm