

Spring Block 2

Length and perimeter

Small steps

Step 1

Measure in kilometres and metres

Step 2

Equivalent lengths (kilometres and metres)

Step 3

Perimeter on a grid

Step 4

Perimeter of a rectangle

Step 5

Perimeter of rectilinear shapes

Step 6

Find missing lengths in rectilinear shapes

Step 7

Calculate perimeter of rectilinear shapes

Step 8

Perimeter of regular polygons



Small steps

Step 9

Perimeter of polygons



Measure in kilometres and metres

Notes and guidance

In previous years, children measured lengths using metres (m) and centimetres (cm). In this small step, children are introduced to kilometres and the abbreviation “km”.

Children should understand that kilometres are greater than metres and are used to measure greater distances. The focus of this step is to partition measurements into the number of kilometres and metres and make links with addition. Bar models and part-whole models can be used to explore this relationship and to support children with their understanding. The fact that $1 \text{ km} = 1,000 \text{ m}$ can be discussed, but conversions are not explicitly covered until the next step.

It is useful to make connections with real-life contexts, so that children are aware when different types of units are used.

Things to look out for

- Children may ignore the unit of measurement and just compare the numbers involved. For example, they might think that 2 km and 60 m is less than 1 km and 700 m, because 260 is less than 1,700
- Children may think that $1 \text{ km} = 100 \text{ m}$, based on the relationship between metres and centimetres.

Key questions

- What unit of measurement would you use to measure the length of a _____? Why?
- What unit of measurement would you use to measure _____? Why?
- Which is the greater length, 1 km or 1 m?
- Which is greater, _____ km and _____ m or _____ km and _____ m? How do you know?
- Which is greater, _____ km or _____ m? How do you know?
- How many kilometres and metres are there in _____ km _____ m?

Possible sentence stems

- _____ km _____ m = _____ km + _____ m
- _____ km and _____ m is greater than _____ km and _____ m.
- _____ km and _____ m is less than _____ km and _____ m.
- There are _____ m in 1 km.

National Curriculum links

- Convert between different units of measure [for example, kilometre to metre; hour to minute]

Measure in kilometres and metres

Key learning

- Sort the cards into the table to show the appropriate unit of measurement.

height of a door frame	length of a room
how far a plane travels	length of a garden
distance from one city to another	length of a table
distance from the bottom to the top of a mountain	
Measured in kilometres	Measured in metres

- Use abbreviations to complete the sentences.

The distance from Rosie's house to school is six kilometres and five hundred metres.

The distance from Rosie's house to school is 6 _____ 500 _____

Jack cycled a total of 8 kilometres and 150 metres to school.

Jack cycled a total of _____ km _____ _____ to school.

- Complete the models.

3 km 300 m		1 km 280 m	
km	300 m	m	1 km

- Which is the greater length, 30 m or 3 km? How do you know?
- Write $<$, $>$ or $=$ to complete the statements.

4 km and 300 m 3 km

9 km and 600 m 9 km + 60 m

5 km and 500 m 2 km + 3 km + 500 m

Measure in kilometres and metres

Reasoning and problem solving

Tiny is measuring the length of a swimming pool.

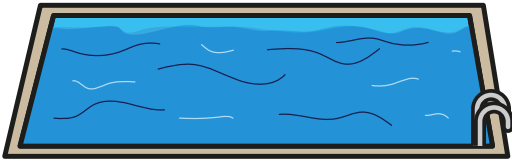

I am going to measure the length in kilometres.

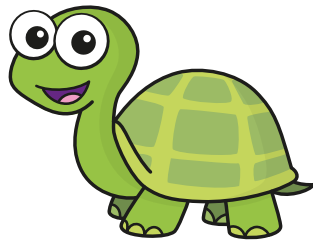

Do you think Tiny has chosen the best unit to measure the length of the pool?

Explain your answer.



No

Teddy walks to his friend's house.



- He walks a whole number of kilometres.
- He walks an odd number of kilometres.
- He walks further than 2 km, but less than 17 km.
- The distance is a multiple of 3

Use the clues to find three possible distances that Teddy walks.

3 km, 9 km
or 15 km

One day, Dora cycles 8 km 200 m.



The next day she cycles 300 m further.

How far does Dora cycle altogether over the two days?

How did you work it out?



16 km 700 m

Equivalent lengths (kilometres and metres)

Notes and guidance

In Year 3, children converted between metres and centimetres, and between centimetres and millimetres. In this small step, children use the fact that 1 km is equal to 1,000 m to derive related facts using numbers up to 10,000

Children make links to counting in 1,000s as covered in their earlier learning on place value.

Bar models, part-whole models and double number lines are useful representations to explore the connections between the two units and to support children with conversions.

Children learnt to multiply and divide by 10 and 100 in the previous block and could extend their thinking to multiply and divide by 1,000; if this is not appropriate, they could count up and down in 1,000s instead.

Things to look out for

- Children may mix up the conversions between different metric units, for example thinking that 1 km = 100 m.
- Children may make errors when counting in 1,000s.
- Children may just consider the numbers and not the units and think that, for example, 70 m is greater than 7 km as 70 is greater than 7

Key questions

- How many metres are there in 1 km?
So how many metres are there in _____ km?
- How can you work out how many metres is equivalent to half a kilometre?
What other fractions of a kilometre can you convert to metres?
- Which is greater, _____ km or _____ m? How do you know?
- What is the same and what is different about converting metres to centimetres and converting kilometres to metres?

Possible sentence stems

- There are _____ m in 1 km, so there are _____ m in _____ km.
- Each kilometre is _____ m, so _____ km is the same as _____ m.
- Every 1,000 m is _____ km, so _____ m is the same as _____ km.
- _____ km and _____ m is the same as _____ m.

National Curriculum links

- Convert between different units of measure [for example, kilometre to metre; hour to minute]

Equivalent lengths (kilometres and metres)

Key learning

- Use the double number line to complete the number sentences.

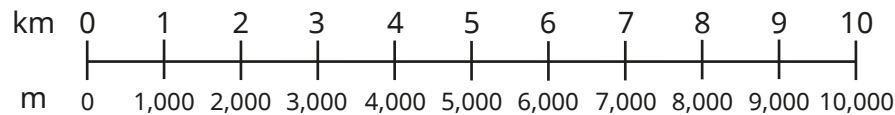

- ▶ 1,000 m = _____ km
- ▶ 3,000 m = _____ km
- ▶ _____ m = 4 km
- ▶ _____ m = 10 km

- Use the bar models to complete the conversions.

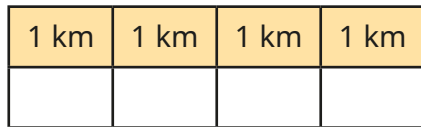

4 km = _____ m

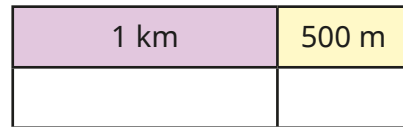

1 km and 500 m = _____ m

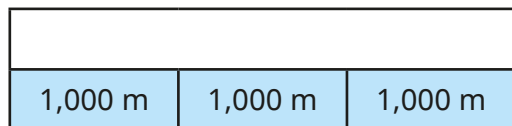

3,000 m = _____ km

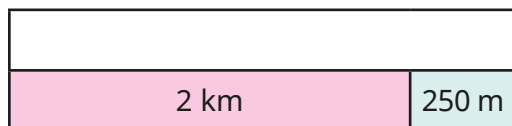

2 km and 250 m = _____ m

- Complete the conversions.

- ▶ 2 km 100 m = _____ m
- ▶ _____ km _____ m = 2,050 m
- ▶ 4 km 300 m = _____ m
- ▶ _____ km _____ m = 4,030 m

- Complete the statement.

800 m + 600 m = _____ m = _____ km _____ m

- Complete the bar models.

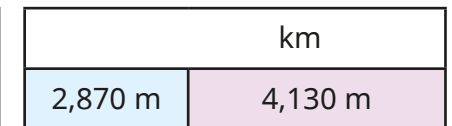
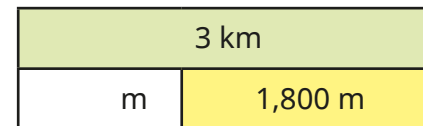

- Write <, > or = to compare the lengths.

6 km and 500 m ○ 6,500 m

4 km ○ 350 m

$\frac{1}{2}$ km ○ 120 m

Equivalent lengths (kilometres and metres)

Reasoning and problem solving

Tom is running a cross-country race.

He runs 800 m as a warm-up.

The race is 5,600 m.

He then does a cool-down of 1 km 200 m.

How far does Tom run in total?

Give your answer in metres.

7,600 m

1,600 m is greater than 6 km.

Do you agree with Tiny?

Explain your answer.

No

Max and Aisha take part in a charity walk.

They walk 15 km altogether.

Aisha walks twice as far as Max.

How far do they each walk?

Max: 5 km
Aisha: 10 km

Max and Aisha both raise £1 for every 500 m they walk.

How much money do they each raise?

Max: £10
Aisha: £20

The flying distance from London to Paris is 342 km 760 m.

The driving distance from London to Paris is 475 km 537 m.

How much further is the driving distance than the flying distance?

132 km 777 m

Perimeter on a grid

Notes and guidance

In Year 3, children were introduced to the idea of perimeter by measuring and calculating the perimeter with labelled side lengths. In this small step, children explore perimeter further with a focus on rectilinear shapes, where all sides meet at right angles. These rectilinear shapes will be drawn on squared grids, mainly centimetre squared grids.

Encourage children to label the lengths of the sides if needed, and to mark off each side as they add the lengths together. Looking at a variety of shapes enables children to compare their perimeters. They also explore drawing different shapes with a specified perimeter. They continue to consider rectilinear shapes only and do not look at diagonal lengths.

Things to look out for

- Children may only add the width and length of one side, or the sides labelled, rather than all the sides of the shape.
- Children may forget to include the unit of measurement.
- Children may count all the squares around the outside of the shape, rather than the lengths of the sides.
- When looking at irregular rectilinear shapes, children may miss some of the sides of the shape.

Key questions

- What does “perimeter” mean?
- What is the length of each square? How do you know?
- What is the length of each side? How do you know?
- What unit is used for the perimeter of your shape?
- How can you make sure you do not include one side twice?
- Which shape has the greater/greatest perimeter?
How do you know?
- Can two different shapes have the same perimeter? How do you know? Can you draw an example to support your answer?

Possible sentence stems

- Perimeter = _____ cm + _____ cm + _____ cm + _____ cm = _____ cm
- The width is _____ cm and the length is _____ cm.
The perimeter of the shape is _____ cm because ...

National Curriculum links

- Measure and calculate the perimeter of a rectilinear figure (including squares) in centimetres and metres

Perimeter on a grid

Key learning

- Work out the perimeters of the shapes.

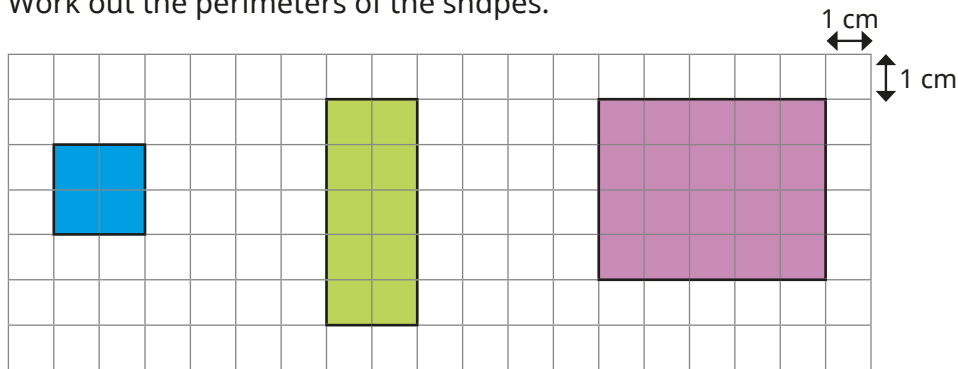

- Two rectilinear shapes are drawn on centimetre squared paper.

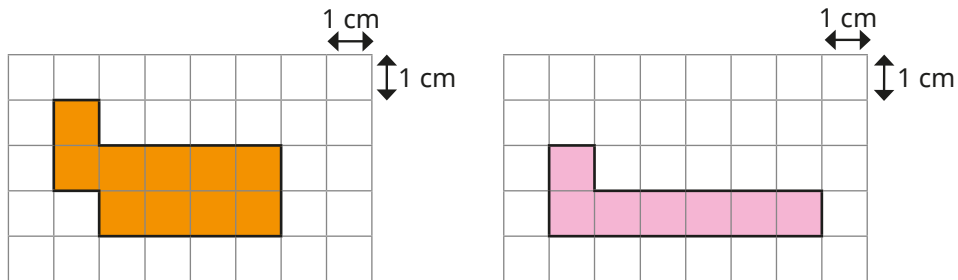

- Are the perimeters of the shapes the same or different?
How do you know?
- Draw a shape with a perimeter that is greater than each of the shapes.

- Work out the perimeters of the shapes.

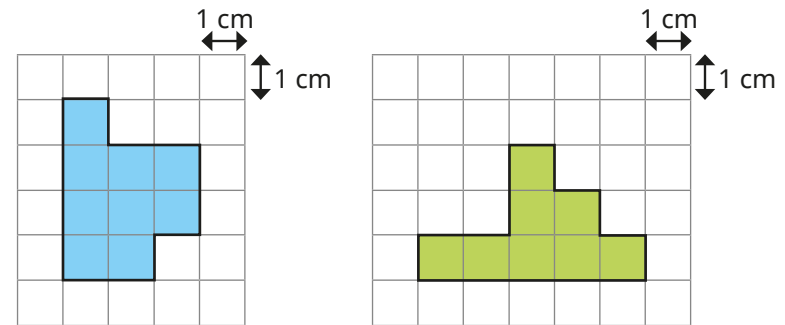

How did you find the perimeters?

- Find the perimeter of each shape.

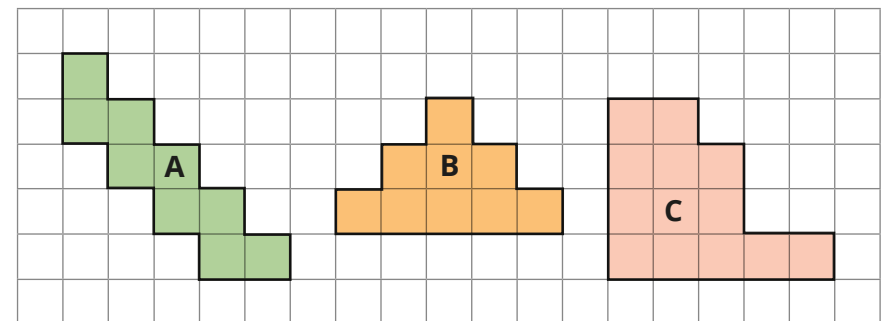

Order the shapes from smallest to greatest perimeter.

- Use centimetre squared paper to draw two different rectilinear shapes, each with a perimeter of 18 cm.

Perimeter on a grid

Reasoning and problem solving

Tiny has worked out the perimeter of the shape to be 22 cm.

22	1	2	3				
21			4	5	6	7	8
20							9
19	18	17	16			11	10
			15	14	13	12	

Is Tiny correct?

Explain your reasoning.

No

The width of a rectangle is 2 cm less than its length.

The perimeter of the rectangle is between 20 cm and 30 cm.

What could the dimensions of the rectangle be?

How many possible rectangles can you find?

length = 6 cm,
width = 4 cm

length = 7 cm,
width = 5 cm

length = 8 cm,
width = 6 cm

Huan has drawn a shape on a centimetre squared grid.

He has spilt some paint on his drawing.

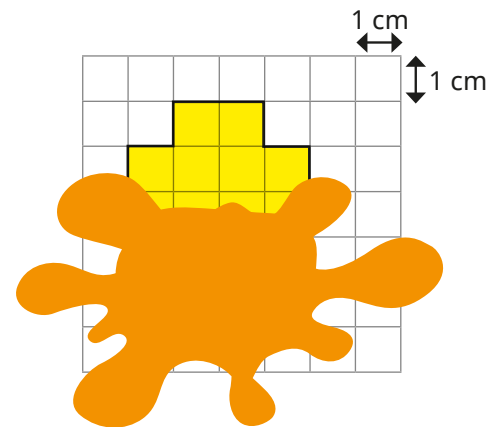

What could the perimeter of the shape be?

Find three possible answers.

What is the smallest possible perimeter?

Explain your answer.

Compare answers as a class.

14 cm

Perimeter of a rectangle

Notes and guidance

In this small step, children focus on calculating the perimeter of rectangles using the side lengths, rather than counting the squares.

Rectangles are first presented on squared grids as they have been seen previously. Children should be encouraged to label the side lengths on the rectangles and discuss anything they notice as they work through some examples. They can then progress to looking at rectangles that are not presented on squared grids but with all four sides labelled, before finally exploring rectangles with only one length and width given.

Children explore different methods for working out the perimeter of rectangles, such as adding double the length to double the width, and doubling the sum of the length and the width.

Things to look out for

- Children may only add the lengths of the sides that are labelled rather than using more efficient methods involving multiplication.
- Children may not check the units given in the diagrams and so fail to convert them if there are mixed units.
- If children do not have efficient strategies for doubling 1- and 2-digit numbers then this may lead to a reliance on inefficient methods.

Key questions

- What is the length of each side? How do you know?
- How can you use the length of each side to calculate the perimeter?
- What is the measurement unit used for the perimeter of the rectangle?
- How did you work out the perimeter of the rectangle? How could you have done it a different way?
- If you know the length and width of a rectangle, do you need to measure/label every side?
- How many different ways can you find the perimeter of this rectangle?

Possible sentence stems

- _____ cm + _____ cm + _____ cm + _____ cm = _____ cm
- $2 \times$ _____ cm + $2 \times$ _____ cm = _____ cm
- $2 \times$ (_____ cm + _____ cm) = _____ cm

National Curriculum links

- Measure and calculate the perimeter of a rectilinear figure (including squares) in centimetres and metres

Perimeter of a rectangle

Key learning

- Work out the perimeters of the rectangles.

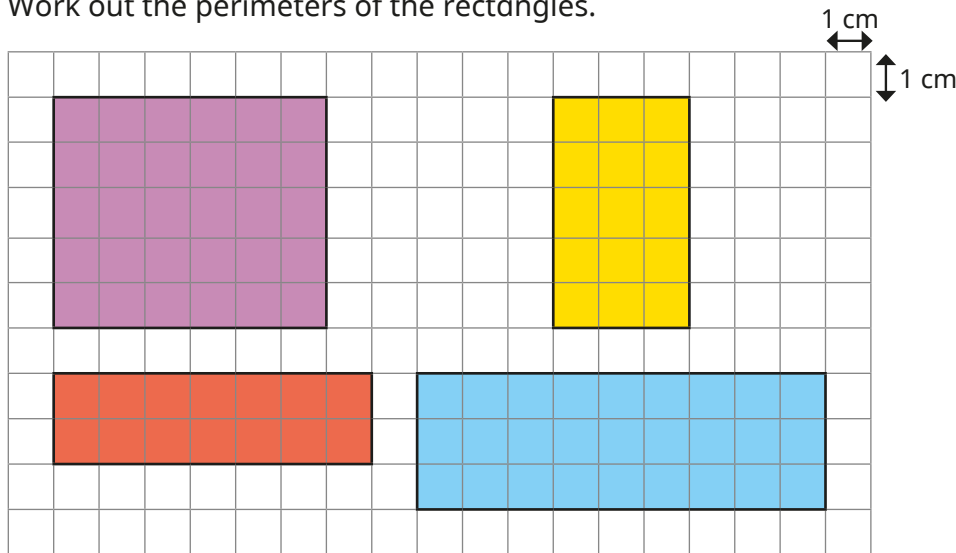

- Work out the perimeter of the rectangle.

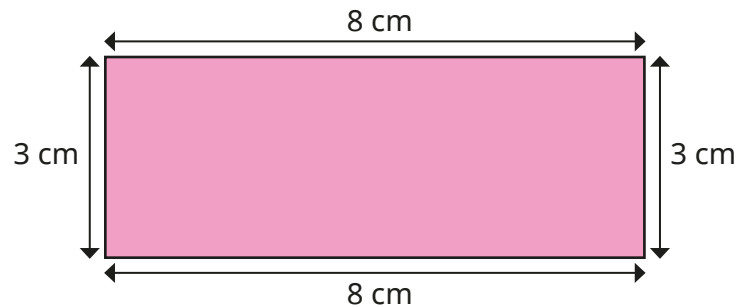

How many different ways can you work out the perimeter?

- Mo and Eva are working out the perimeter of the rectangle.

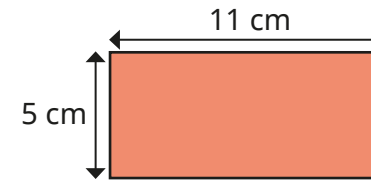

Mo

$$5 \text{ cm} + 11 \text{ cm} = 16 \text{ cm}$$

$$16 \text{ cm} \times 2 = 32 \text{ cm}$$

Eva

$$5 \text{ cm} + 5 \text{ cm} = 10 \text{ cm}$$

$$11 \text{ cm} + 11 \text{ cm} = 22 \text{ cm}$$

$$10 + 22 = 32 \text{ cm}$$

What is the same and what is different about their methods?

- Work out the perimeters of the rectangles.

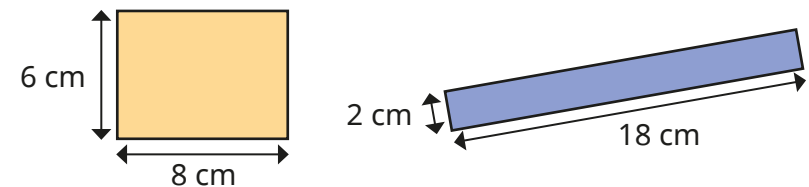

Compare methods with a partner.

- The perimeter of a rectangle is 30 cm.
The length of the rectangle is 11 cm.
What is the width of the rectangle?

Perimeter of a rectangle

Reasoning and problem solving

Whitney makes a rectangle using pencils.

Each pencil is 11 cm long.

What is the perimeter of the rectangle?

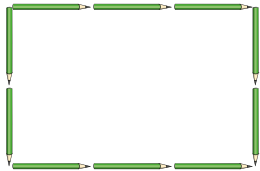

110 cm

Mo is describing a square.

Use the clues to work out the perimeter of the square.

- The perimeter is a 2-digit even number less than 50
- The sum of the digits of the perimeter is 9
- The side length is a whole number of metres.

36 m

Is the statement always true, sometimes true or never true?

When the sides of a rectangle are all odd numbers, the perimeter is an even number.

Explain your answer.

always true

Mrs Trent is working out the perimeter of her garden.

- The length of the garden is double its width.
- The width of the garden is a multiple of 3
- The perimeter of the garden is less than 40

What could the length, width and perimeter of Mrs Trent's garden be?

Find all the possible answers.

6 m long,
3 m wide,
perimeter 18 m

12 m long,
6 m wide,
perimeter 36 m

Perimeter of rectilinear shapes

Notes and guidance

This small step continues to build children's understanding of perimeter by exploring more rectilinear shapes, both with and without grids.

Children know that a rectilinear shape has straight lines that meet at right angles. In this step, it is useful for children to measure the perimeter practically before they find the perimeter of a shape on a grid or from a shape with all side lengths labelled. When calculating, children should mark the sides they have already counted to avoid duplication or omission.

At this stage, children do not need to calculate unknown side lengths as this will be covered in the next step.

Things to look out for

- Children may make arithmetical errors when adding the side lengths.
- Children may omit sides or count them more than once.
- When working on a grid, children may count the number of squares around the shape rather than the side lengths.
- Children may add the side lengths and double them, as they did when calculating the perimeters of rectangles.

Key questions

- What is a rectilinear shape?
- How many sides does the shape have?
- Are any of the sides equal in length?
- What strategies can you use to find the perimeter?
- How can you be sure you have included all the sides?
- How can you check your answer?
- How many rectilinear shapes can you draw with a perimeter of _____ cm?

Possible sentence stems

- The calculation I need to do to work out the perimeter is ...
- The shape has _____ sides, so I need to add together _____ lengths to find the perimeter.
- The perimeter of the shape is _____ mm/cm/m.

National Curriculum links

- Measure and calculate the perimeter of a rectilinear figure (including squares) in centimetres and metres

Perimeter of rectilinear shapes

Key learning

- Annie has made some shapes using lolly sticks.

How many lolly sticks have been used to make each shape?

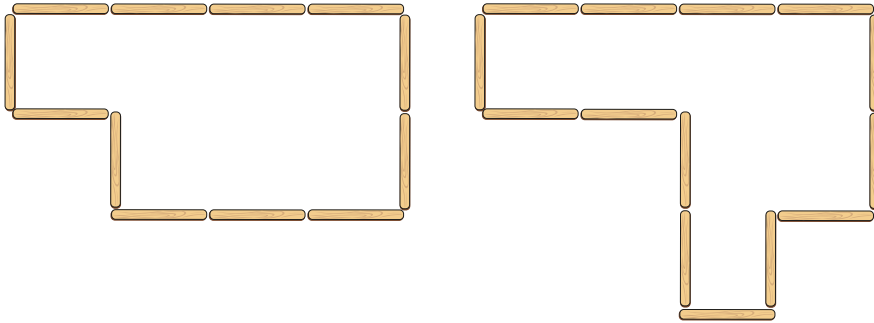

Which shape has the greater perimeter?

Use 12 lolly sticks to create different rectilinear shapes.

- Work out the perimeters of the shapes.

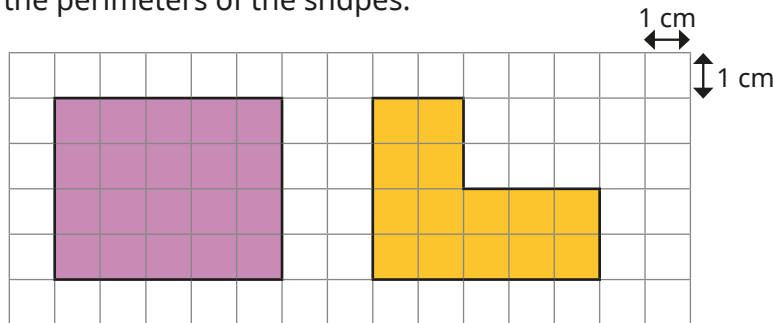

What do you notice?

- Work out the perimeters of the shapes.

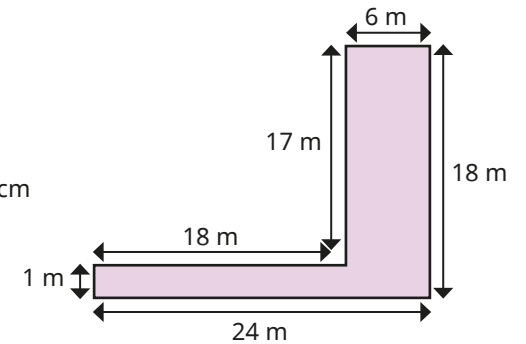
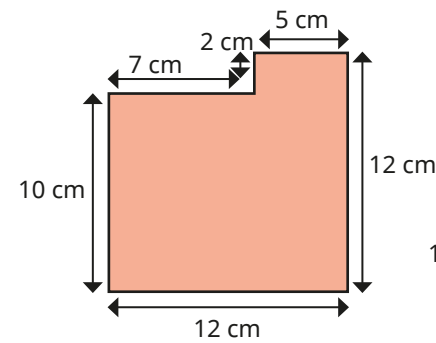
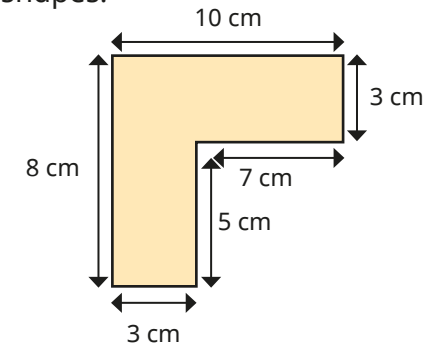
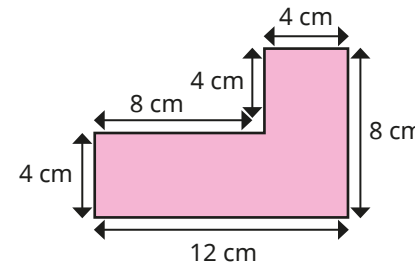

- How many rectilinear shapes can you draw that have a perimeter of 24 cm?

How many sides do they each have?

What is the length of the longest side of each of your shapes?

What is the length of the shortest side of each of your shapes?

Perimeter of rectilinear shapes

Reasoning and problem solving



Tiny has measured the lengths of the sides of the shape.

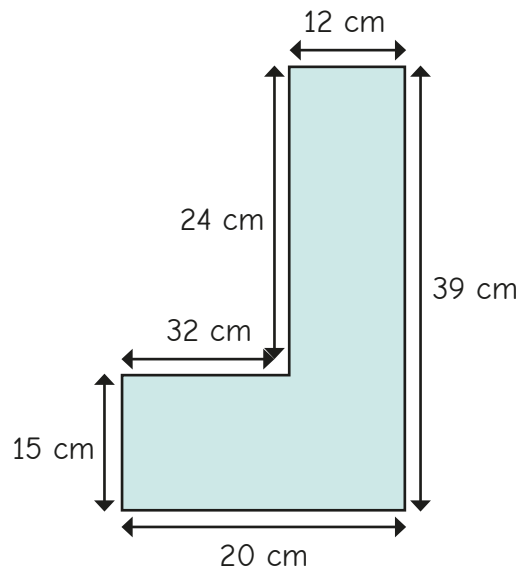

The side labelled 20 cm is longer than the side labelled 32 cm.

How can you tell that Tiny has made a mistake?

Ron has drawn some letters on a grid.
Which letter has the greater perimeter?

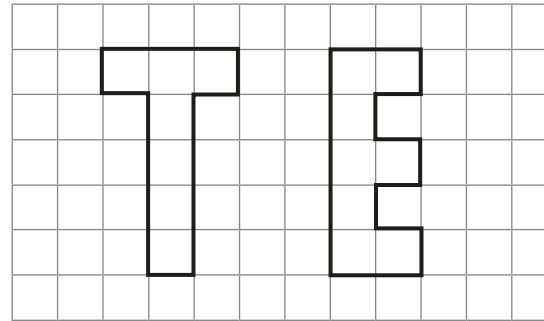

Explore other letters that can be drawn as rectilinear shapes.

Put them in order from smallest to greatest perimeter.

Compare answers with a partner.



E
E = 18 units,
T = 16 units

multiple possible answers

Find missing lengths in rectilinear shapes

Notes and guidance

In this small step, children continue to look at rectilinear shapes, focusing on finding missing side lengths.

Children explore the relationship between the sides of a rectilinear shape, rather than finding the perimeter. They start by using addition to find the missing side lengths, then using subtraction and finally using both operations to find more than one missing side length. Part-whole models may be useful here.

Children may find it helpful to draw the shapes and measure them, enabling them to notice that the opposite sides of the shapes are related. They could cut pieces of string or thin strips of paper to see which parts of a side correspond to another side.

Things to look out for

- Children may need support to notice the relationships between the sides.
- Children may use the wrong operation to find the missing side length, for example adding two sides instead of subtracting them.
- The words “horizontal” and “vertical” may be unfamiliar.

Key questions

- What lengths do you know?
What lengths do you need to find out?
- What is the total horizontal length of the shape?
Which sides add together to give the same total?
- What is the total vertical length of the shape?
Which sides add together to give the same total?
- Do you need to add or subtract to find the missing length?
How do you know?
- Are you finding a part or a whole?

Possible sentence stems

- _____ + _____ = _____
- _____ = _____ - _____
- The missing side length is _____ because ...

National Curriculum links

- Measure and calculate the perimeter of a rectilinear figure (including squares) in centimetres and metres

Find missing lengths in rectilinear shapes

Key learning

- Find the missing lengths on the shapes.

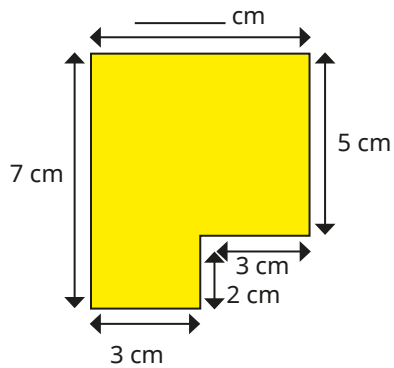

$$3 \text{ cm} + 3 \text{ cm} = \text{_____ cm}$$

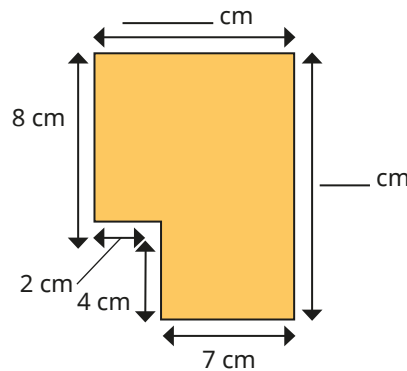

$$7 \text{ cm} + 2 \text{ cm} = \text{_____ cm}$$

$$8 \text{ cm} + 4 \text{ cm} = \text{_____ cm}$$

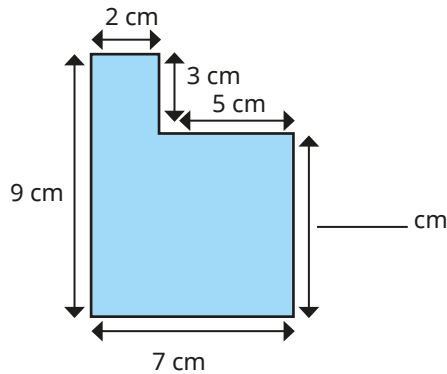

$$9 \text{ cm} - 3 \text{ cm} = \text{_____ cm}$$

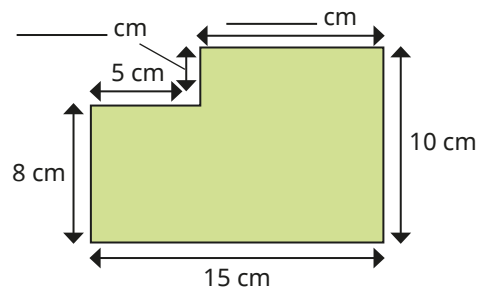

$$15 \text{ cm} - 5 \text{ cm} = \text{_____ cm}$$

$$10 \text{ cm} - 8 \text{ cm} = \text{_____ cm}$$

- Find the missing lengths on the shapes.

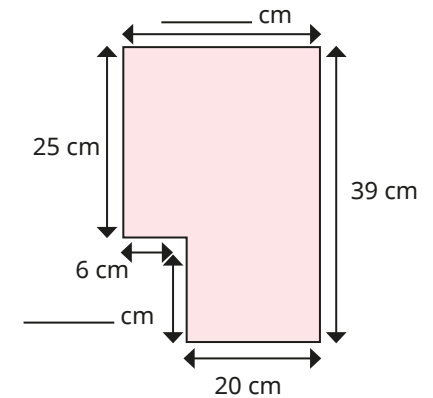
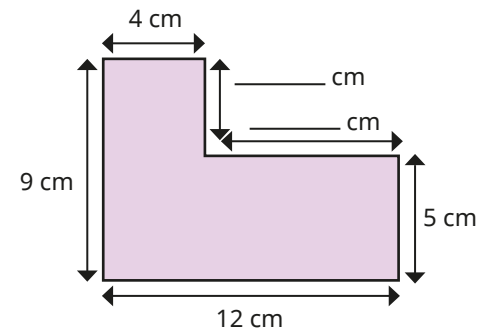

- Alex has made a shape with three identical rectangles.

Each rectangle is 20 cm long and 10 cm wide.

Work out the lengths of all eight sides of Alex's shape.

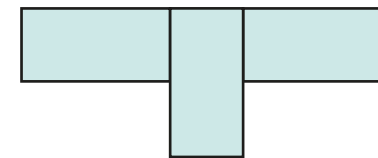



How would your answers change if the rectangles were 24 cm long and 12 cm wide?

Find missing lengths in rectilinear shapes

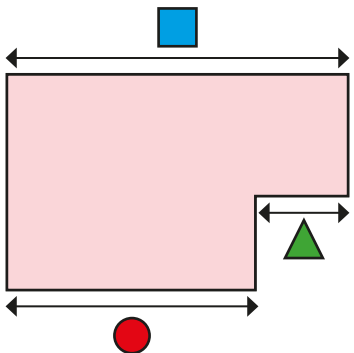
Reasoning and problem solving



The length of side  is equal to the total length of side  and side .

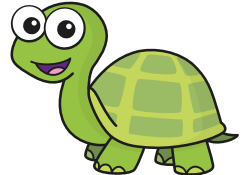

Is Tiny correct?
Explain your answer.

Yes

Mr Lee wants to wallpaper this room.

He knows the lengths of some walls, but not all of them.

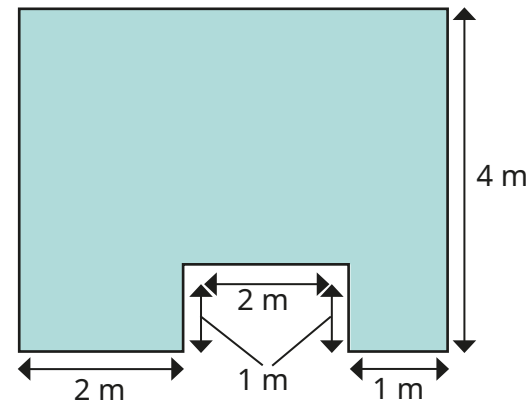

left side: 4 m
top side: 5 m

Explain how Mr Lee can work out the unknown lengths.

What are the unknown lengths?

Calculate the perimeter of rectilinear shapes

Notes and guidance

Building on the previous step, children move on to calculating the perimeter of rectilinear shapes where they first need to find the missing length(s). This could involve addition or subtraction depending on the information given in the question.

Children identify equivalent sides and, after calculating any unknown lengths, annotate the shape, ensuring that every side is labelled. This helps to prevent errors or omissions when calculating the perimeter.

Children also work backwards from a given perimeter to work out an unknown side length.

Things to look out for

- Children may need support to identify equivalent sides.
- Children may use the wrong operation to find the missing length. For example, they may add together two sides rather than subtract them.
- When finding the perimeter of a complex rectilinear shape, children may miss a side when adding, or add the same side twice.

Key questions

- What lengths do you know?
What lengths do you need to find out?
- What is the total horizontal/vertical length of the shape?
Which sides add together to give the same total?
- Where is the missing length on the shape?
- How many missing lengths are there on the shape?
- Do you need to add or subtract to find the missing length?
How do you know?
- Are you finding a part or a whole?

Possible sentence stems

- The side measuring _____ and the side measuring _____ are equal to the side measuring _____
- To work out the unknown length, I need to _____ because ...
- There are _____ sides, so I need to add together _____ lengths to find the perimeter.

National Curriculum links

- Measure and calculate the perimeter of a rectilinear figure (including squares) in centimetres and metres

Calculate the perimeter of rectilinear shapes

Key learning

- Work out the perimeters of the rectilinear shapes.

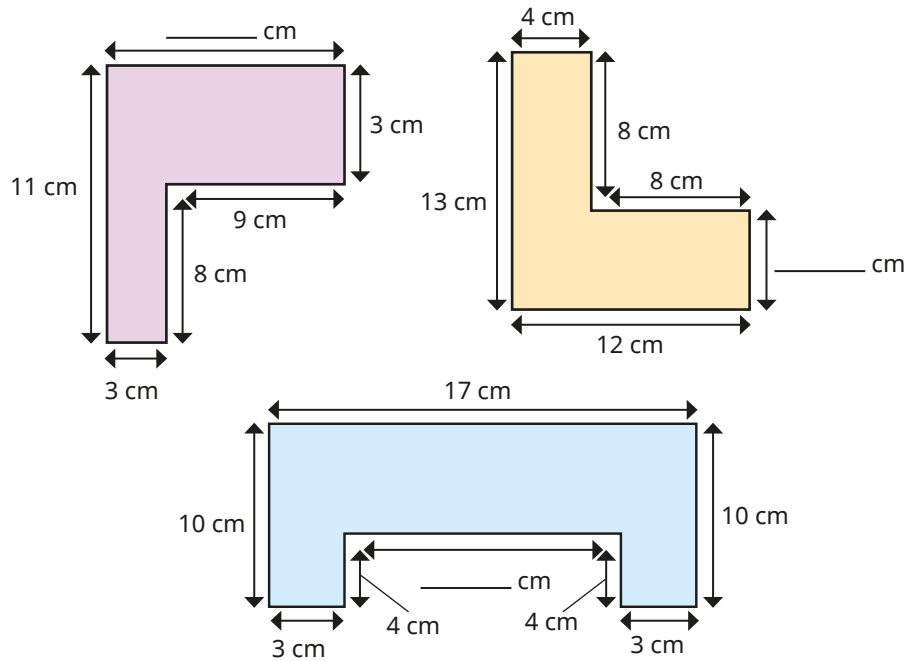

- Find the unknown lengths and the perimeter of the rectilinear shape.

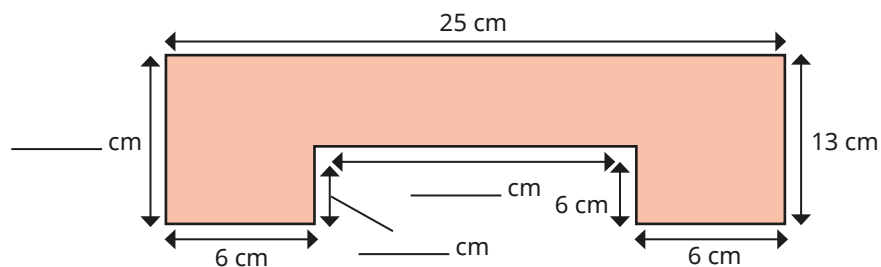

- Work out the perimeter of this shape.

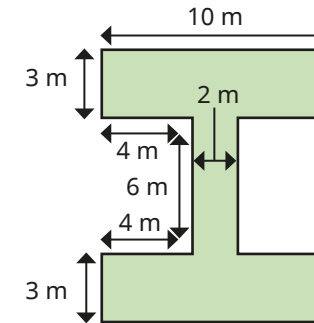

How did you work out the perimeter?

Compare methods with a partner.

- The perimeter of this rectilinear shape is 44 cm.

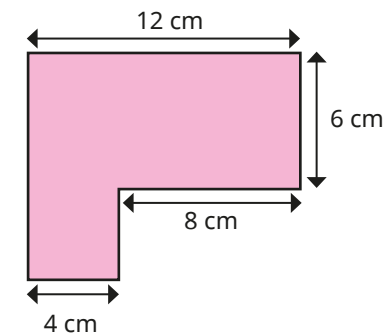

Work out the unknown lengths.

Calculate the perimeter of rectilinear shapes

Reasoning and problem solving

The length of one side of a square is 12 cm.

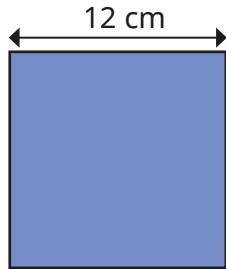

The square is cut in half to make two rectangles.

The two halves are put together to make this shape.

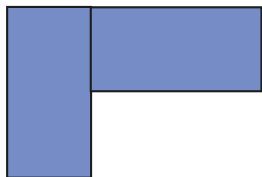

What is the perimeter of the new shape?

How did you work it out?

60 cm

△, ▲, ● and ■ all represent whole numbers.

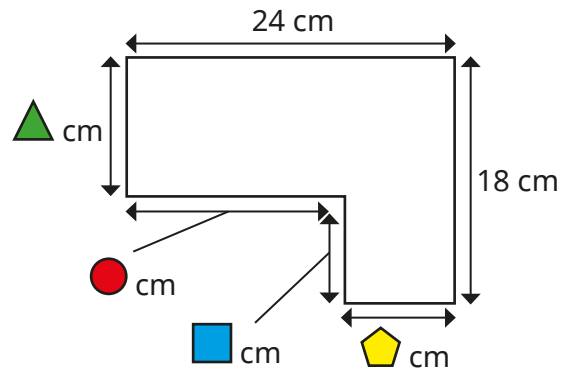

What could the value of ▲ and ■ be?

What could the value of ● and ▲ be?

Using these values, what is the perimeter of the rectilinear shape?

Experiment for other values.

What do you notice?

multiple possible answers, e.g.

▲ = 13 and ■ = 5

● = 18 and ▲ = 6

The perimeter is 84 cm.

Perimeter of regular polygons

Notes and guidance

In this small step, children are introduced to the term “regular polygon” for the first time. Explain that, in a regular polygon, all sides are equal in length and the angles are equal in size. For this step, children only need to understand that a regular polygon has equal side lengths, as they will not be exposed to shapes that have the same side lengths with different angles.

Children use the equality of sides to calculate the perimeter of regular polygons by making links with repeated addition and/or multiplication facts. Similarly, they use division to find the length of one side of a regular polygon when given its perimeter.

Children may need reminding that a polygon is a flat shape with straight sides.

Things to look out for

- Children may need support to learn the names of different polygons and the number of sides they have.
- Children need to be secure with multiplication and division facts.
- Children may misunderstand the word “regular” and think that, for example, a rectangle is regular.

Key questions

- What is a polygon?
- How do you know if a polygon is regular?
- If one side is _____ cm, what is the length of each of the other sides of the shape? How can you find the perimeter?
- Is an equilateral triangle a regular shape?
- Is a rectangle a regular shape?
- If you know the perimeter of a regular polygon, how can you work out the length of each side?

Possible sentence stems

- Each side is _____ cm.
There are _____ sides, so the perimeter of the polygon is _____ × _____ cm = _____ cm.
- _____ cm + _____ cm + _____ cm = 3 × _____ cm
= _____ cm

National Curriculum links

- This small step is not taken from the Year 4 National Curriculum. It is included to take into account the non-statutory DfE Ready to Progress guidance.

Perimeter of regular polygons

Key learning

- A polygon is regular if all its sides are equal in length and all its angles are equal in size.

Which of these polygons are regular?

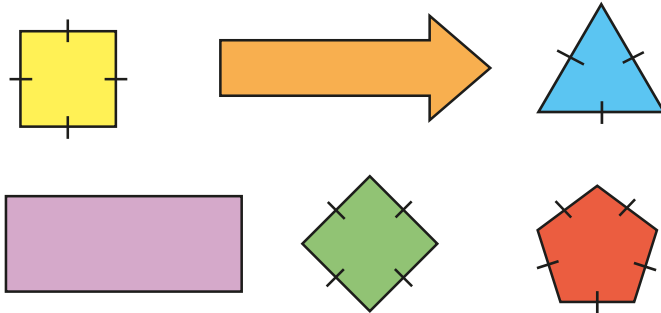

- Work out the perimeters of the regular polygons.

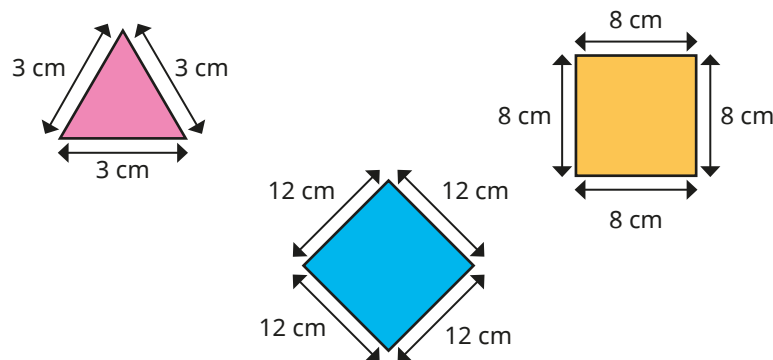

How did you work out the perimeters?

- Tommy has found a rule to work out the perimeter of a regular polygon.

$$\text{perimeter} = \text{number of sides} \times \text{length of one side}$$

Use this rule to work out the perimeters of these regular polygons.

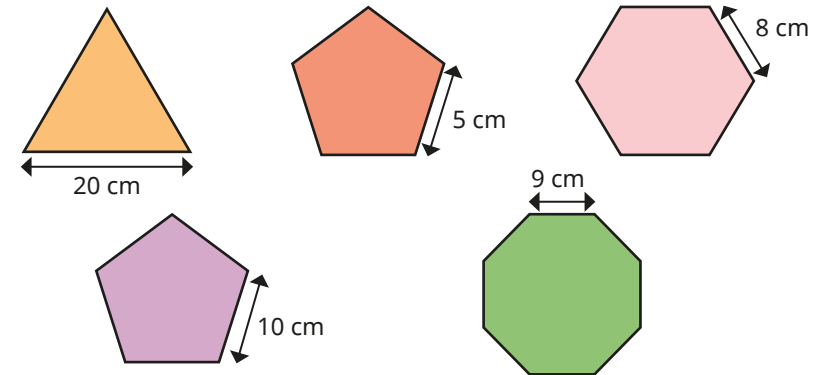

- Which has the greater perimeter?

a square with a side length of 12 cm

a regular octagon with a side length of 6 cm

Perimeter of regular polygons

Reasoning and problem solving

The perimeter of an equilateral triangle is 45 cm.

Work out the length of each side of the triangle.

15 cm

The perimeter of a regular pentagon is 60 cm.

Work out the length of each side of the pentagon.

12 cm

Filip has drawn some regular polygons.

Each polygon has a perimeter of 40 cm.

All the sides measure whole numbers of centimetres.

How many sides might the polygon have?

Compare answers with a partner.

4, 5, 8, 10, 20, 40

Dani has joined together three regular decagons to make a new shape.

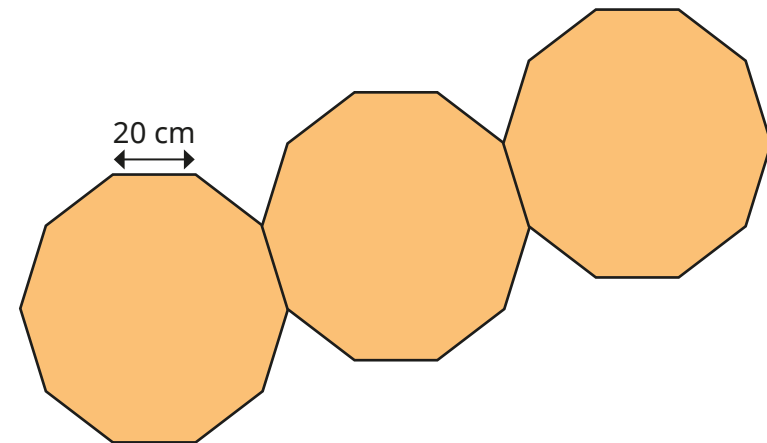

What is the perimeter of the new shape?

How did you work it out?

Talk about it with a partner.

520 cm

Perimeter of polygons

Notes and guidance

In this small step, children learn the word “irregular” to describe polygons that are not regular. Show children a range of irregular shapes to help them to identify that either the lengths or angles, or both, are not all equal. In this step, children are exposed to examples of polygons in which the lengths are equal but angles are not, and this is an important discussion point.

Children continue to add the side lengths together to find the perimeter. Encourage children to use number bonds to add related sides (for example, $4\text{ cm} + 6\text{ cm} = 10\text{ cm}$) when working out the perimeter, as this will make calculating more efficient. They also use symmetry and properties of shapes to label lengths that are not given to help them calculate perimeters of shapes that are partially labelled.

Children should still label and mark sides as they are working out perimeters to help avoid errors.

Things to look out for

- Children may try to measure unknown sides rather than use the given information to work out the lengths.
- When finding the perimeter of a more complex shape, children may omit some of the sides, or count them more than once.

Key questions

- What is the difference between a regular and an irregular polygon?
- Is the shape irregular? How do you know?
- How can you work out the perimeter of the shape?
- Are any of the sides the same length?
- What is the length of each side?
- How can you work out the perimeter more efficiently?
- If the shape is symmetrical, how can this help you to work out some of the missing side lengths?

Possible sentence stems

- The shape is regular/irregular because ...
- There are _____ sides, so I need to add together _____ lengths to work out the perimeter.
- The calculation I need to do to work out the perimeter is ...

National Curriculum links

- This small step is not taken from the Year 4 National Curriculum. It is included to take into account the non-statutory DfE Ready to Progress guidance.

Perimeter of polygons

Key learning

- Mo uses lolly sticks to make some polygons. Each stick is 6 cm long.

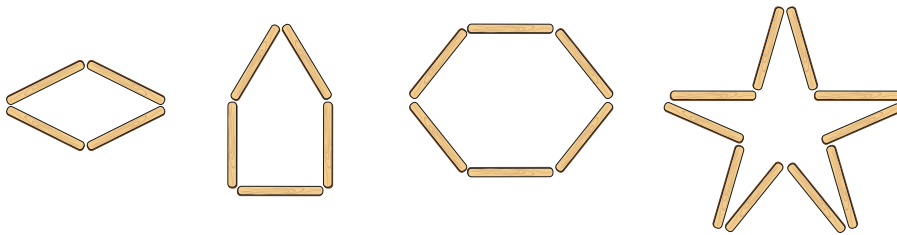

Work out the perimeters of the shapes.

Are any of the shapes regular? How can you tell?

- Work out the perimeters of these hexagons.

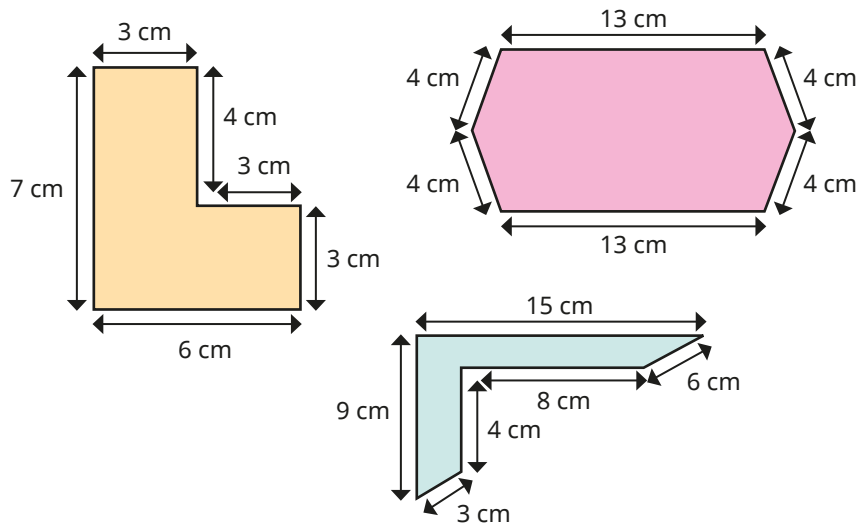

- All the shapes have one line of symmetry. Work out the perimeters of the shapes.

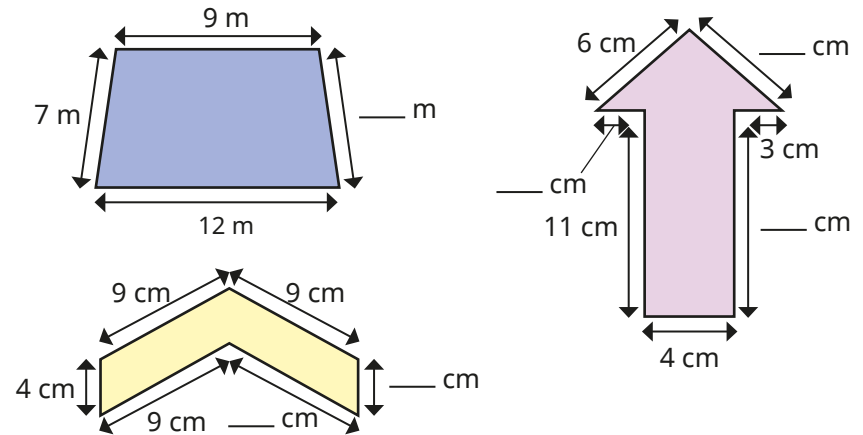

- The perimeter of this triangle is 19 cm. Work out the unknown length.

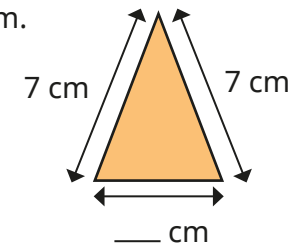

- The perimeter of a rectangle is 22 cm. The length of the rectangle is 8 cm. Work out the width of the rectangle.

Perimeter of polygons

Reasoning and problem solving

I have enough information to work out the perimeter of this shape.

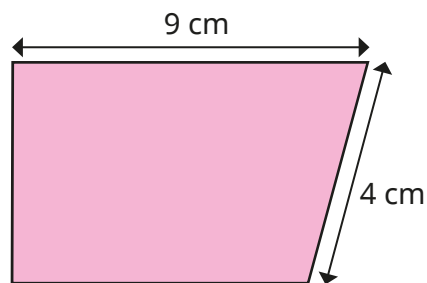
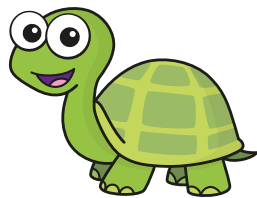

Do you agree with Tiny?
Explain your answer.

No

The perimeter of a rectangle is 18 cm.

Each side is a whole number of centimetres.

The side marked is longer than the side marked .

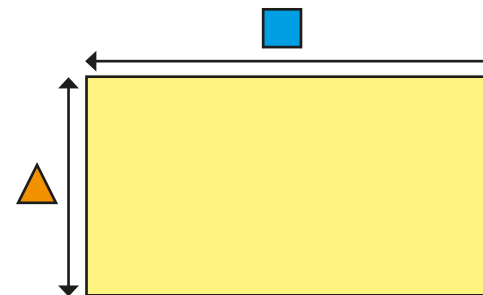

- = 8, = 1
- = 7, = 2
- = 6, = 3
- = 5, = 4

What could be the lengths of and .

Find as many possibilities as you can.

What do you notice?